

## PRESCRIBING INFORMATION

### **ADVAIR<sup>®</sup> HFA 45/21**

(fluticasone propionate 45 mcg and salmeterol 21 mcg\*)

Inhalation Aerosol

### **ADVAIR<sup>®</sup> HFA 115/21**

(fluticasone propionate 115 mcg and salmeterol 21 mcg\*)

Inhalation Aerosol

### **ADVAIR<sup>®</sup> HFA 230/21**

(fluticasone propionate 230 mcg and salmeterol 21 mcg\*)

Inhalation Aerosol

\*As salmeterol xinafoate salt 30.45 mcg, equivalent to salmeterol base 21 mcg

### **For Oral Inhalation Only**

#### **WARNING**

Long-acting beta<sub>2</sub>-adrenergic agonists, such as salmeterol, one of the active ingredients in ADVAIR HFA, may increase the risk of asthma-related death. Therefore, when treating patients with asthma, physicians should only prescribe ADVAIR HFA for patients not adequately controlled on other asthma-controller medications (e.g., low- to medium-dose inhaled corticosteroids) or whose disease severity clearly warrants initiation of treatment with 2 maintenance therapies. Data from a large placebo-controlled US study that compared the safety of salmeterol (SEREVENT<sup>®</sup> Inhalation Aerosol) or placebo added to usual asthma therapy showed an increase in asthma-related deaths in patients receiving salmeterol (13 deaths out of 13,176 patients treated for 28 weeks on salmeterol versus 3 deaths out of 13,179 patients on placebo) (see WARNINGS).

#### **DESCRIPTION**

ADVAIR HFA 45/21 Inhalation Aerosol, ADVAIR HFA 115/21 Inhalation Aerosol, and ADVAIR HFA 230/21 Inhalation Aerosol are combinations of fluticasone propionate and salmeterol xinafoate.

One active component of ADVAIR HFA is fluticasone propionate, a corticosteroid having the chemical name *S*-(fluoromethyl) 6 $\alpha$ ,9-difluoro-11 $\beta$ ,17-dihydroxy-16 $\alpha$ -methyl-3-oxoandrosta-1,4-diene-17 $\beta$ -carbothioate, 17-propionate and the following chemical structure:

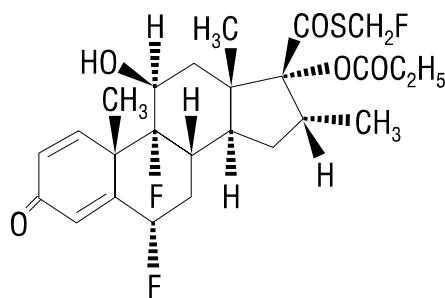

Fluticasone propionate is a white powder with a molecular weight of 500.6, and the empirical formula is  $C_{25}H_{31}F_3O_5S$ . It is practically insoluble in water, freely soluble in dimethyl sulfoxide and dimethylformamide, and slightly soluble in methanol and 95% ethanol.

The other active component of ADVAIR HFA is salmeterol xinafoate, a beta<sub>2</sub>-adrenergic bronchodilator. Salmeterol xinafoate is the racemic form of the 1-hydroxy-2-naphthoic acid salt of salmeterol. The chemical name of salmeterol xinafoate is 4-hydroxy- $\alpha^1$ -[[[6-(4-phenylbutoxy)hexyl]amino]methyl]-1,3-benzenedimethanol, 1-hydroxy-2-naphthalenecarboxylate, and it has the following chemical structure:

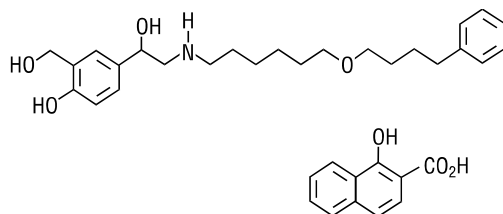

Salmeterol xinafoate is a white powder with a molecular weight of 603.8, and the empirical formula is  $C_{25}H_{37}NO_4 \cdot C_{11}H_8O_3$ . It is freely soluble in methanol; slightly soluble in ethanol, chloroform, and isopropanol; and sparingly soluble in water.

ADVAIR HFA 45/21 Inhalation Aerosol, ADVAIR HFA 115/21 Inhalation Aerosol, and ADVAIR HFA 230/21 Inhalation Aerosol are pressurized metered-dose aerosol units fitted with a counter. ADVAIR HFA is intended for oral inhalation only. Each unit contains a microcrystalline suspension of fluticasone propionate (micronized) and salmeterol xinafoate (micronized) in propellant HFA-134a (1,1,1,2-tetrafluoroethane). It contains no other excipients.

After priming, each actuation of the inhaler delivers 50, 125, or 250 mcg of fluticasone propionate and 25 mcg of salmeterol in 75 mg of suspension from the valve. Each actuation delivers 45, 115, or 230 mcg of fluticasone propionate and 21 mcg of salmeterol from the actuator. Twenty-one micrograms (21 mcg) of salmeterol base is equivalent to 30.45 mcg of salmeterol xinafoate. The actual amount of drug delivered to the lung may depend on patient factors, such as the coordination between the actuation of the device and inspiration through the delivery system.

Each 12-g canister provides 120 inhalations.

ADVAIR HFA should be primed before using for the first time by releasing 4 test sprays into the air away from the face, shaking well for 5 seconds before each spray. In cases where the inhaler has not been used for more than 4 weeks or when it has been dropped, prime the inhaler again by releasing 2 test sprays into the air away from the face, shaking well for 5 seconds before each spray.

This product does not contain any chlorofluorocarbon (CFC) as the propellant.

## CLINICAL PHARMACOLOGY

**Mechanism of Action: *ADVAIR HFA Inhalation Aerosol:*** Since ADVAIR HFA contains both fluticasone propionate and salmeterol, the mechanisms of action described below for the individual components apply to ADVAIR HFA. These drugs represent 2 classes of medications (a synthetic corticosteroid and a selective, long-acting beta<sub>2</sub>-adrenergic receptor agonist) that have different effects on clinical, physiologic, and inflammatory indices of asthma.

***Fluticasone Propionate:*** Fluticasone propionate is a synthetic trifluorinated corticosteroid with potent anti-inflammatory activity. In vitro assays using human lung cytosol preparations have established fluticasone propionate as a human glucocorticoid receptor agonist with an affinity 18 times greater than dexamethasone, almost twice that of beclomethasone-17-monopropionate (BMP), the active metabolite of beclomethasone dipropionate, and over 3 times that of budesonide. Data from the McKenzie vasoconstrictor assay in man are consistent with these results.

Inflammation is an important component in the pathogenesis of asthma. Corticosteroids have been shown to inhibit multiple cell types (e.g., mast cells, eosinophils, basophils, lymphocytes, macrophages, and neutrophils) and mediator production or secretion (e.g., histamine, eicosanoids, leukotrienes, and cytokines) involved in the asthmatic response. These anti-inflammatory actions of corticosteroids contribute to their efficacy in asthma.

***Salmeterol Xinafoate:*** Salmeterol is a long-acting beta<sub>2</sub>-adrenergic agonist. In vitro studies and in vivo pharmacologic studies demonstrate that salmeterol is selective for beta<sub>2</sub>-adrenoceptors compared with isoproterenol, which has approximately equal agonist activity on beta<sub>1</sub>- and beta<sub>2</sub>-adrenoceptors. In vitro studies show salmeterol to be at least 50 times more selective for beta<sub>2</sub>-adrenoceptors than albuterol. Although beta<sub>2</sub>-adrenoceptors are the predominant adrenergic receptors in bronchial smooth muscle and beta<sub>1</sub>-adrenoceptors are the predominant receptors in the heart, there are also beta<sub>2</sub>-adrenoceptors in the human heart comprising 10% to 50% of the total beta-adrenoceptors. The precise function of these receptors has not been established, but their presence raises the possibility that even selective beta<sub>2</sub>-agonists may have cardiac effects.

The pharmacologic effects of beta<sub>2</sub>-adrenoceptor agonist drugs, including salmeterol, are at least in part attributable to stimulation of intracellular adenylyl cyclase, the enzyme that catalyzes the conversion of adenosine triphosphate (ATP) to cyclic-3',5'-adenosine monophosphate (cyclic AMP). Increased cyclic AMP levels cause relaxation of bronchial smooth muscle and inhibition of release of mediators of immediate hypersensitivity from cells, especially from mast cells.

In vitro tests show that salmeterol is a potent and long-lasting inhibitor of the release of mast cell mediators, such as histamine, leukotrienes, and prostaglandin D<sub>2</sub>, from human lung. Salmeterol inhibits histamine-induced plasma protein extravasation and inhibits platelet activating factor-induced eosinophil accumulation in the lungs of guinea pigs when administered by the inhaled route. In humans, single doses of salmeterol administered via inhalation aerosol attenuate allergen-induced bronchial hyper-responsiveness.

**Preclinical:** In animals and humans, propellant HFA-134a was found to be rapidly absorbed and rapidly eliminated, with an elimination half-life of 3 to 27 minutes in animals and 5 to 7 minutes in humans. Time to maximum plasma concentration (T<sub>max</sub>) and mean residence time are both extremely short, leading to a transient appearance of HFA-134a in the blood with no evidence of accumulation.

Propellant HFA-134a is devoid of pharmacological activity except at very high doses in animals (i.e., 380 to 1,300 times the maximum human exposure based on comparisons of area under the plasma concentration versus time curve [AUC] values), primarily producing ataxia, tremors, dyspnea, or salivation. These events are similar to effects produced by the structurally related CFCs, which have been used extensively in metered-dose inhalers. In drug interaction studies in male and female dogs, there was a slight increase in the salmeterol-related effect on heart rate (a known effect of beta<sub>2</sub>-agonists) when given in combination with high doses of fluticasone propionate. This effect was not observed in clinical studies.

**Pharmacokinetics: ADVAIR HFA Inhalation Aerosol:** Three single-dose, placebo-controlled, crossover studies were conducted in healthy subjects: (1) a study using 4 inhalations of ADVAIR HFA 230/21, salmeterol CFC inhalation aerosol 21 mcg, or fluticasone propionate CFC inhalation aerosol 220 mcg, (2) a study using 8 inhalations of ADVAIR HFA 45/21, ADVAIR HFA 115/21, or ADVAIR HFA 230/21, and (3) a study using 4 inhalations of ADVAIR HFA 230/21; 2 inhalations of ADVAIR DISKUS<sup>®</sup> 500/50 (fluticasone propionate 500 mcg and salmeterol 50 mcg inhalation powder); 4 inhalations of fluticasone propionate CFC inhalation aerosol 220 mcg; or 1,010 mcg of fluticasone propionate given intravenously. Peak plasma concentrations of fluticasone propionate were achieved in 0.33 to 1.5 hours and those of salmeterol were achieved in 5 to 10 minutes.

Peak plasma concentrations of fluticasone propionate (N = 20 subjects) following 8 inhalations of ADVAIR HFA 45/21, ADVAIR HFA 115/21, and ADVAIR HFA 230/21 averaged 41, 108, and 173 pg/mL, respectively. Peak plasma salmeterol concentrations ranged from 220 to 470 pg/mL.

Systemic exposure (N = 20 subjects) from 4 inhalations of ADVAIR HFA 230/21 was 53% of the value from the individual inhaler for fluticasone propionate CFC inhalation aerosol and 42% of the value from the individual inhaler for salmeterol CFC inhalation aerosol. Peak plasma concentrations from ADVAIR HFA for fluticasone propionate (86 vs. 120 pg/mL) and salmeterol (170 vs. 510 pg/mL) were significantly lower compared with individual inhalers.

In 15 healthy subjects, systemic exposure to fluticasone propionate from 4 inhalations of ADVAIR HFA 230/21 (920/84 mcg) and 2 inhalations of ADVAIR DISKUS 500/50

(1,000/100 mcg) were similar between the 2 inhalers (i.e., 799 vs. 832 pg•h/mL, respectively) but approximately half the systemic exposure from 4 inhalations of fluticasone propionate CFC inhalation aerosol 220 mcg (880 mcg, AUC = 1,543 pg•h/mL). Similar results were observed for peak fluticasone propionate plasma concentrations (186 and 182 pg/mL from ADVAIR HFA and ADVAIR DISKUS, respectively, and 307 pg/mL from the fluticasone propionate CFC inhalation aerosol). Systemic exposure to salmeterol was higher (317 vs. 169 pg•h/mL) and peak salmeterol concentrations were lower (196 vs. 223 pg/mL) following ADVAIR HFA compared with ADVAIR DISKUS, although pharmacodynamic results were comparable.

Absolute bioavailability of fluticasone propionate from ADVAIR HFA in 15 healthy subjects was 5.3%. Terminal half-life estimates of fluticasone propionate for ADVAIR HFA, ADVAIR DISKUS, and fluticasone propionate CFC inhalation aerosol were similar and averaged 5.6 hours. No terminal half-life estimates were calculated for salmeterol.

A double-blind crossover study was conducted in 13 adult patients with asthma to evaluate the steady-state pharmacokinetics of fluticasone propionate and salmeterol following administration of 2 inhalations of ADVAIR HFA 115/21 twice daily or 1 inhalation of ADVAIR DISKUS 250/50 twice daily for 4 weeks. Systemic exposure (AUC) to fluticasone propionate was similar for ADVAIR HFA (274 pg•h/mL [95% CI 150, 502]) and ADVAIR DISKUS (338 pg•h/mL [95% CI 197, 581]). Systemic exposure to salmeterol was also similar for ADVAIR HFA (53 pg•h/mL [95% CI 17, 164]) and ADVAIR DISKUS (70 pg•h/mL [95% CI 19, 254]).

**Special Populations: Hepatic and Renal Impairment:** Formal pharmacokinetic studies using ADVAIR HFA have not been conducted to examine gender differences or in special populations, such as elderly patients or patients with hepatic or renal impairment. However, since both fluticasone propionate and salmeterol are predominantly cleared by hepatic metabolism, impairment of liver function may lead to accumulation of fluticasone propionate and salmeterol in plasma. Therefore, patients with hepatic disease should be closely monitored.

**Drug Interactions:** In repeat- and single-dose studies, there was no evidence of significant drug interaction on systemic exposure to fluticasone propionate and salmeterol when given alone or in combination via the DISKUS. Similar definitive studies have not been performed with ADVAIR HFA.

**Fluticasone Propionate: Absorption:** Fluticasone propionate acts locally in the lung; therefore, plasma levels do not predict therapeutic effect. Studies using oral dosing of labeled and unlabeled drug have demonstrated that the oral systemic bioavailability of fluticasone propionate is negligible (<1%), primarily due to incomplete absorption and presystemic metabolism in the gut and liver. In contrast, the majority of the fluticasone propionate delivered to the lung is systemically absorbed.

**Distribution:** Following intravenous administration, the initial disposition phase for fluticasone propionate was rapid and consistent with its high lipid solubility and tissue binding. The volume of distribution averaged 4.2 L/kg.

The percentage of fluticasone propionate bound to human plasma proteins averages 99%. Fluticasone propionate is weakly and reversibly bound to erythrocytes and is not significantly bound to human transcortin.

**Metabolism:** The total clearance of fluticasone propionate is high (average, 1,093 mL/min), with renal clearance accounting for less than 0.02% of the total. The only circulating metabolite detected in man is the 17 $\beta$ -carboxylic acid derivative of fluticasone propionate, which is formed through the cytochrome P450 3A4 pathway. This metabolite had less affinity (approximately 1/2,000) than the parent drug for the glucocorticoid receptor of human lung cytosol in vitro and negligible pharmacological activity in animal studies. Other metabolites detected in vitro using cultured human hepatoma cells have not been detected in man.

**Elimination:** Following intravenous dosing, fluticasone propionate showed polyexponential kinetics and had a terminal elimination half-life of approximately 7.8 hours. Less than 5% of a radiolabeled oral dose was excreted in the urine as metabolites, with the remainder excreted in the feces as parent drug and metabolites.

**Special Populations: Gender:** In 19 male and 33 female patients with asthma, systemic exposure was similar from 2 inhalations of fluticasone propionate CFC inhalation aerosol 44, 110, and 220 mcg twice daily.

**Drug Interactions:** Fluticasone propionate is a substrate of cytochrome P450 3A4. Coadministration of fluticasone propionate and the strong cytochrome P450 3A4 inhibitor ritonavir is not recommended based upon a multiple-dose, crossover drug interaction study in 18 healthy subjects. Fluticasone propionate aqueous nasal spray (200 mcg once daily) was coadministered for 7 days with ritonavir (100 mg twice daily). Plasma fluticasone propionate concentrations following fluticasone propionate aqueous nasal spray alone were undetectable (<10 pg/mL) in most subjects, and when concentrations were detectable, peak levels ( $C_{max}$ ) averaged 11.9 pg/mL (range, 10.8 to 14.1 pg/mL) and  $AUC_{(0-\tau)}$  averaged 8.43 pg•hr/mL (range, 4.2 to 18.8 pg•hr/mL). Fluticasone propionate  $C_{max}$  and  $AUC_{(0-\tau)}$  increased to 318 pg/mL (range, 110 to 648 pg/mL) and 3,102.6 pg•hr/mL (range, 1,207.1 to 5,662.0 pg•hr/mL), respectively, after coadministration of ritonavir with fluticasone propionate aqueous nasal spray. This significant increase in systemic fluticasone propionate exposure resulted in a significant decrease (86%) in serum cortisol AUC.

Caution should be exercised when other strong cytochrome P450 3A4 inhibitors are coadministered with fluticasone propionate. In a drug interaction study, coadministration of orally inhaled fluticasone propionate (1,000 mcg) and ketoconazole (200 mg once daily) resulted in increased systemic fluticasone propionate exposure and reduced plasma cortisol AUC, but had no effect on urinary excretion of cortisol.

In another multiple-dose drug interaction study, coadministration of orally inhaled fluticasone propionate (500 mcg twice daily) and erythromycin (333 mg 3 times daily) did not affect fluticasone propionate pharmacokinetics.

**Salmeterol Xinafoate:** Salmeterol xinafoate, an ionic salt, dissociates in solution so that the salmeterol and 1-hydroxy-2-naphthoic acid (xinafoate) moieties are absorbed, distributed, metabolized, and excreted independently. Salmeterol acts locally in the lung; therefore, plasma levels do not predict therapeutic effect.

**Absorption:** Because of the small therapeutic dose, systemic levels of salmeterol are low or undetectable after inhalation of recommended dosages (42 mcg of salmeterol inhalation aerosol twice daily). Following chronic administration of an inhaled dosage of 42 mcg twice daily, salmeterol was detected in plasma within 5 to 10 minutes in 6 patients with asthma; plasma concentrations were very low, with mean peak concentrations of 150 pg/mL and no accumulation with repeated doses.

**Distribution:** The percentage of salmeterol bound to human plasma proteins averages 96% in vitro over the concentration range of 8 to 7,722 ng of salmeterol base per milliliter, much higher concentrations than those achieved following therapeutic doses of salmeterol.

**Metabolism:** Salmeterol base is extensively metabolized by hydroxylation, with subsequent elimination predominately in the feces. No significant amount of unchanged salmeterol base was detected in either urine or feces.

An in vitro study using human liver microsomes showed that salmeterol is extensively metabolized to  $\alpha$ -hydroxysalmeterol (aliphatic oxidation) by cytochrome P450 3A4 (CYP3A4). Ketoconazole, a strong inhibitor of CYP3A4, essentially completely inhibited the formation of  $\alpha$ -hydroxysalmeterol in vitro.

**Elimination:** In 2 healthy adult subjects who received 1 mg of radiolabeled salmeterol (as salmeterol xinafoate) orally, approximately 25% and 60% of the radiolabeled salmeterol was eliminated in urine and feces, respectively, over a period of 7 days. The terminal elimination half-life was about 5.5 hours (1 volunteer only).

The xinafoate moiety has no apparent pharmacologic activity. The xinafoate moiety is highly protein bound (>99%) and has a long elimination half-life of 11 days.

**Drug Interactions:** Salmeterol is a substrate of CYP3A4.

**Inhibitors of Cytochrome P450 3A4: Ketoconazole:** In a placebo-controlled, crossover drug interaction study in 20 healthy male and female subjects, coadministration of salmeterol (50 mcg twice daily) and the strong CYP3A4 inhibitor ketoconazole (400 mg once daily) for 7 days resulted in a significant increase in plasma salmeterol exposure as determined by a 16-fold increase in AUC (ratio with and without ketoconazole 15.76; 90% CI: 10.66, 23.31) mainly due to increased bioavailability of the swallowed portion of the dose. Peak plasma salmeterol concentrations were increased by 1.4-fold (90% CI: 1.23, 1.68). Three (3) out of 20 subjects (15%) were withdrawn from salmeterol and ketoconazole coadministration due to beta-agonist-mediated systemic effects (2 with QTc prolongation and 1 with palpitations and sinus tachycardia). Coadministration of salmeterol and ketoconazole did not result in a clinically significant effect on mean heart rate, mean blood potassium, or mean blood glucose. Although there was no statistical effect on the mean QTc, coadministration of salmeterol and ketoconazole was associated with more frequent increases in QTc duration compared with salmeterol and

placebo administration. Due to the potential increased risk of cardiovascular adverse events, the concomitant use of salmeterol with strong CYP3A4 inhibitors (e.g., ketoconazole, ritonavir, atazanavir, clarithromycin, indinavir, itraconazole, nefazodone, nelfinavir, saquinavir, telithromycin) is not recommended.

**Erythromycin:** In a repeat-dose study in 13 healthy subjects, concomitant administration of erythromycin (a moderate CYP3A4 inhibitor) and salmeterol inhalation aerosol resulted in a 40% increase in salmeterol  $C_{max}$  at steady state (ratio with and without erythromycin 1.4; 90% CI: 0.96, 2.03;  $p = 0.12$ ), a 3.6-beat/min increase in heart rate (95% CI: 0.19, 7.03;  $p < 0.04$ ), a 5.8-msec increase in QTc interval (95% CI: -6.14, 17.77;  $p = 0.34$ ), and no change in plasma potassium.

**Pharmacodynamics: ADVAIR HFA Inhalation Aerosol:** Since systemic pharmacodynamic effects of salmeterol are not normally seen at the therapeutic dose, higher doses were used to produce measurable effects. Four placebo-controlled, crossover studies were conducted in healthy subjects: (1) a cumulative-dose study using 42 to 336 mcg of salmeterol CFC inhalation aerosol given alone or as ADVAIR HFA 115/21, (2) a single-dose study using 4 inhalations of ADVAIR HFA 230/21, salmeterol CFC inhalation aerosol 21 mcg, or fluticasone propionate CFC inhalation aerosol 220 mcg, (3) a single-dose study using 8 inhalations of ADVAIR HFA 45/21, ADVAIR HFA 115/21, or ADVAIR HFA 230/21, and (4) a single-dose study using 4 inhalations of ADVAIR HFA 230/21; 2 inhalations of ADVAIR DISKUS 500/50; 4 inhalations of fluticasone propionate CFC inhalation aerosol 220 mcg; or 1,010 mcg of fluticasone propionate given intravenously. In these studies pulse rate, blood pressure, QTc interval, glucose, and/or potassium were measured. Comparable or lower effects were observed for ADVAIR HFA compared with ADVAIR DISKUS or salmeterol alone. The effect of salmeterol on pulse rate and potassium was not altered by the presence of different amounts of fluticasone propionate in ADVAIR HFA. The potential effect of salmeterol on the effects of fluticasone propionate on the hypothalamic-pituitary-adrenal (HPA) axis was also evaluated in 3 of these studies. Compared with fluticasone propionate CFC inhalation aerosol, ADVAIR HFA had less effect on 24-hour urinary cortisol excretion and less or comparable effect on 24-hour serum cortisol. In these crossover studies in healthy subjects, ADVAIR HFA and ADVAIR DISKUS had similar effects on urinary and serum cortisol.

In clinical studies with ADVAIR HFA in patients with asthma, systemic pharmacodynamic effects of salmeterol (pulse rate, blood pressure, QTc interval, potassium, and glucose) were similar to or slightly lower in patients treated with ADVAIR HFA compared with patients treated with salmeterol CFC inhalation aerosol 21 mcg. In 61 adolescent and adult patients with asthma given ADVAIR HFA (45/21 or 115/21 mcg), continuous 24-hour electrocardiographic monitoring was performed after the first dose and after 12 weeks of twice-daily therapy, and no clinically significant dysrhythmias were noted.

A 4-way crossover study in 13 patients with asthma compared pharmacodynamics at steady state following 4 weeks of twice-daily treatment with 2 inhalations of ADVAIR HFA 115/21, 1 inhalation of ADVAIR DISKUS 250/50 mcg, 2 inhalations of fluticasone propionate HFA

inhalation aerosol 110 mcg, and placebo. No significant differences in serum cortisol AUC were observed between active treatments and placebo. Mean 12-hour serum cortisol AUC ratios comparing active treatment with placebo ranged from 0.9 to 1.2. No statistically or clinically significant increases in heart rate or QTc interval were observed for any active treatment compared with placebo.

In a 12-week study (see CLINICAL TRIALS: Studies Comparing ADVAIR HFA With Fluticasone Propionate Alone or Salmeterol Alone: *Study 3*) in patients with asthma, ADVAIR HFA 115/21 was compared with the individual components, fluticasone propionate CFC inhalation aerosol 110 mcg and salmeterol CFC inhalation aerosol 21 mcg, and placebo. All treatments were administered as 2 inhalations twice daily. After 12 weeks of treatment with these therapeutic doses, the geometric mean ratio of urinary cortisol excretion compared with baseline was 0.9 for ADVAIR HFA and fluticasone propionate and 1.0 for placebo and salmeterol. In addition, the ability to increase cortisol production in response to stress, as assessed by 30-minute cosyntropin stimulation in 23 to 32 patients per treatment group, remained intact for the majority of patients and was similar across treatments. Three patients who received ADVAIR HFA 115/21 had an abnormal response (peak serum cortisol <18 mcg/dL) after dosing, compared with 1 patient who received placebo, 2 patients who received fluticasone propionate 110 mcg, and 1 patient who received salmeterol.

In another 12-week study (see CLINICAL TRIALS: Studies Comparing ADVAIR HFA With Fluticasone Propionate Alone or Salmeterol Alone: *Study 4*) in patients with asthma, ADVAIR HFA 230/21 (2 inhalations twice daily) was compared with ADVAIR DISKUS 500/50 (1 inhalation twice daily) and fluticasone propionate CFC inhalation aerosol 220 mcg (2 inhalations twice daily). The geometric mean ratio of 24-hour urinary cortisol excretion at week 12 compared with baseline was 0.9 for all 3 treatment groups.

**Fluticasone Propionate:** In clinical trials with fluticasone propionate inhalation powder using dosages up to and including 250 mcg twice daily, occasional abnormal short cosyntropin tests (peak serum cortisol <18 mcg/dL) were noted both in patients receiving fluticasone propionate and in patients receiving placebo. The incidence of abnormal tests at 500 mcg twice daily was greater than placebo. In a 2-year study carried out in 64 patients with mild, persistent asthma (mean FEV<sub>1</sub> 91% of predicted) randomized to fluticasone propionate 500 mcg twice daily or placebo, no patient receiving fluticasone propionate had an abnormal response to 6-hour cosyntropin infusion (peak serum cortisol <18 mcg/dL). With a peak cortisol threshold of <35 mcg/dL, 1 patient receiving fluticasone propionate (4%) had an abnormal response at 1 year; repeat testing at 18 months and 2 years was normal. Another patient receiving fluticasone propionate (5%) had an abnormal response at 2 years. No patient on placebo had an abnormal response at 1 or 2 years.

**Salmeterol Xinafoate:** Inhaled salmeterol, like other beta-adrenergic agonist drugs, can produce dose-related cardiovascular effects and effects on blood glucose and/or serum potassium in some patients (see PRECAUTIONS). The cardiovascular effects (heart rate, blood pressure)

associated with salmeterol occur with similar frequency, and are of similar type and severity, as those noted following albuterol administration.

The effects of rising inhaled doses of salmeterol and standard inhaled doses of albuterol were studied in volunteers and in patients with asthma. Salmeterol doses up to 84 mcg resulted in heart rate increases of 3 to 16 beats/min, about the same as albuterol dosed at 180 mcg by inhalation aerosol (4 to 10 beats/min). In 2 double-blind asthma studies, patients receiving either 42 mcg of salmeterol inhalation aerosol twice daily (n = 81) or 180 mcg of albuterol inhalation aerosol 4 times daily (n = 80) underwent continuous electrocardiographic monitoring during four 24-hour periods; no clinically significant dysrhythmias were noted.

Studies in laboratory animals (minipigs, rodents, and dogs) have demonstrated the occurrence of cardiac arrhythmias and sudden death (with histologic evidence of myocardial necrosis) when beta-agonists and methylxanthines are administered concurrently. The clinical significance of these findings is unknown.

## **CLINICAL TRIALS**

ADVAIR HFA has been studied in patients with asthma 12 years of age and older. ADVAIR HFA has not been studied in patients under 12 years of age or in patients with chronic obstructive pulmonary disease (COPD). In clinical trials comparing ADVAIR HFA Inhalation Aerosol with the individual components, improvements in most efficacy endpoints were greater with ADVAIR HFA than with the use of either fluticasone propionate or salmeterol alone. In addition, clinical trials showed comparable results between ADVAIR HFA and ADVAIR DISKUS.

### **Studies Comparing ADVAIR HFA With Fluticasone Propionate Alone or**

**Salmeterol Alone:** Four (4) double-blind, parallel-group clinical trials were conducted with ADVAIR HFA in 1,517 adolescent and adult patients ( $\geq 12$  years, mean baseline forced expiratory volume in 1 second [FEV<sub>1</sub>] 65% to 75% of predicted normal) with asthma that was not optimally controlled on their current therapy. All metered-dose inhaler treatments were inhalation aerosols given as 2 inhalations twice daily, and other maintenance therapies were discontinued.

**Study 1: Clinical Trial With ADVAIR HFA 45/21 Inhalation Aerosol:** This placebo-controlled, 12-week, US study compared ADVAIR HFA 45/21 with fluticasone propionate CFC inhalation aerosol 44 mcg or salmeterol CFC inhalation aerosol 21 mcg, each given as 2 inhalations twice daily. The primary efficacy endpoints were predose FEV<sub>1</sub> and withdrawals due to worsening asthma. This study was stratified according to baseline asthma therapy: patients using beta-agonists (albuterol alone [n = 142], salmeterol [n = 84], or inhaled corticosteroids [n = 134] [daily doses of beclomethasone dipropionate 252 to 336 mcg; budesonide 400 to 600 mcg; flunisolide 1,000 mcg; fluticasone propionate inhalation aerosol 176 mcg; fluticasone propionate inhalation powder 200 mcg; or triamcinolone acetonide 600 to 800 mcg]). Baseline FEV<sub>1</sub> measurements were similar across treatments: ADVAIR HFA 45/21, 2.29 L; fluticasone propionate 44 mcg, 2.20 L; salmeterol, 2.33 L; and placebo, 2.27 L.

Predefined withdrawal criteria for lack of efficacy, an indicator of worsening asthma, were utilized for this placebo-controlled study. Worsening asthma was defined as a clinically important decrease in FEV<sub>1</sub> or peak expiratory flow (PEF), increase in use of VENTOLIN<sup>®</sup> (albuterol, USP) Inhalation Aerosol, increase in night awakenings due to asthma, emergency intervention or hospitalization due to asthma, or requirement for asthma medication not allowed by the protocol. As shown in Table 1, statistically significantly fewer patients receiving ADVAIR HFA 45/21 were withdrawn due to worsening asthma compared with salmeterol and placebo. Fewer patients receiving ADVAIR HFA 45/21 were withdrawn due to worsening asthma compared with fluticasone propionate 44 mcg; however, the difference was not statistically significant.

**Table 1. Percent of Patients Withdrawn Due to Worsening Asthma in Patients Previously Treated With Beta<sub>2</sub>-Agonists (Albuterol or Salmeterol) or Inhaled Corticosteroids (Study 1)**

ADVAIR HFA 45/21 (n = 92)	Fluticasone Propionate CFC Inhalation Aerosol 44 mcg (n = 89)	Salmeterol CFC Inhalation Aerosol 21 mcg (n = 92)	Placebo HFA Inhalation Aerosol (n = 87)
2%	8%	25%	28%

The FEV<sub>1</sub> results are displayed in Figure 1. Because this trial used predetermined criteria for worsening asthma, which caused more patients in the placebo group to be withdrawn, FEV<sub>1</sub> results at Endpoint (last available FEV<sub>1</sub> result) are also provided. Patients receiving ADVAIR HFA 45/21 had significantly greater improvements in FEV<sub>1</sub> (0.58 L, 27%) compared with fluticasone propionate 44 mcg (0.36 L, 18%), salmeterol (0.25 L, 12%), and placebo (0.14 L, 5%). These improvements in FEV<sub>1</sub> with ADVAIR HFA 45/21 were achieved regardless of baseline asthma therapy (albuterol alone, salmeterol, or inhaled corticosteroids).

**Figure 1. Mean Percent Change From Baseline in FEV<sub>1</sub> in Patients Previously Treated With Either Beta<sub>2</sub>-Agonists (Albuterol or Salmeterol) or Inhaled Corticosteroids (Study 1)**

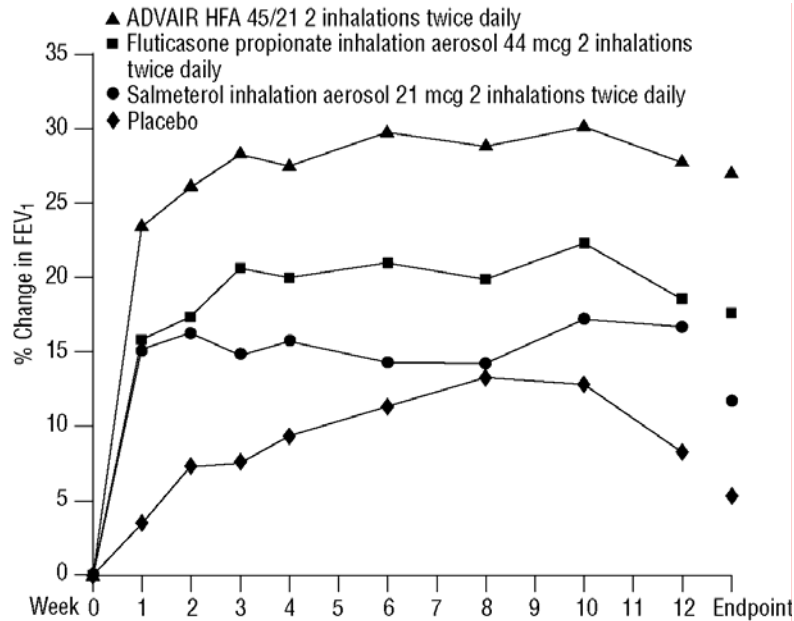

	Week 0	Week 6	Endpoint
	<u>N</u>	<u>N</u>	<u>N</u>
ADVAIR HFA 45/21	92	88	85
Fluticasone propionate inhalation aerosol 44 mcg	89	84	76
Salmeterol inhalation aerosol 21 mcg	92	72	65
Placebo	87	63	58

The effect of ADVAIR HFA 45/21 on the secondary efficacy parameters, including morning and evening PEF, usage of VENTOLIN Inhalation Aerosol, and asthma symptoms over 24 hours on a scale of 0 to 5 is shown in Table 2.

**Table 2. Secondary Efficacy Variable Results for Patients Previously Treated With Beta<sub>2</sub>-Agonists (Albuterol or Salmeterol) or Inhaled Corticosteroids (Study 1)**

Efficacy Variable *	ADVAIR HFA 45/21 (n = 92)	Fluticasone Propionate CFC Inhalation Aerosol 44 mcg (n = 89)	Salmeterol CFC Inhalation Aerosol 21 mcg (n = 92)	Placebo HFA Inhalation Aerosol (n = 87)
AM PEF (L/min)				
Baseline	377	369	381	382
Change from baseline	58	27	25	1
PM PEF (L/min)				
Baseline	397	387	402	407
Change from baseline	48	20	16	3
Use of VENTOLIN Inhalation Aerosol (inhalations/day)				
Baseline	3.1	2.4	2.7	2.7
Change from baseline	-2.1	-0.4	-0.8	0.2
Asthma symptom score/day				
Baseline	1.8	1.6	1.7	1.7
Change from baseline	-1.0	-0.3	-0.4	0

\*Change from baseline = change from baseline at Endpoint (last available data).

The subjective impact of asthma on patients' perceptions of health was evaluated through use of an instrument called the Asthma Quality of Life Questionnaire (AQLQ) (based on a 7-point scale where 1 = maximum impairment and 7 = none). Patients receiving ADVAIR HFA 45/21 had clinically meaningful improvements in overall asthma-specific quality of life as defined by a difference between groups of  $\geq 0.5$  points in change from baseline AQLQ scores (difference in AQLQ score of 1.14 [95% CI 0.85, 1.44] compared with placebo).

**Study 2: Clinical Trial With ADVAIR HFA 45/21 Inhalation Aerosol:** This active-controlled, 12-week, US study compared ADVAIR HFA 45/21 with fluticasone propionate CFC inhalation aerosol 44 mcg and salmeterol CFC inhalation aerosol 21 mcg, each given as 2 inhalations twice daily, in 283 patients using as-needed albuterol alone. The primary efficacy endpoint was predose FEV<sub>1</sub>. Baseline FEV<sub>1</sub> measurements were similar across treatments: ADVAIR HFA 45/21, 2.37 L; fluticasone propionate 44 mcg, 2.31 L; and salmeterol, 2.34 L.

Efficacy results in this study were similar to those observed in Study 1. Patients receiving ADVAIR HFA 45/21 had significantly greater improvements in FEV<sub>1</sub> (0.69 L, 33%) compared with fluticasone propionate 44 mcg (0.51 L, 25%) and salmeterol (0.47 L, 22%).

**Study 3: Clinical Trial With ADVAIR HFA 115/21 Inhalation Aerosol:** This placebo-controlled, 12-week, US study compared ADVAIR HFA 115/21 with fluticasone propionate CFC inhalation aerosol 110 mcg or salmeterol CFC inhalation aerosol 21 mcg, each given as 2 inhalations twice daily, in 365 patients using inhaled corticosteroids (daily doses of beclomethasone dipropionate 378 to 840 mcg; budesonide 800 to 1,200 mcg; flunisolide 1,250 to 2,000 mcg; fluticasone propionate inhalation aerosol 440 to 660 mcg; fluticasone propionate inhalation powder 400 to 600 mcg; or triamcinolone acetonide 900 to 1,600 mcg). The primary efficacy endpoints were predose FEV<sub>1</sub> and withdrawals due to worsening asthma. Baseline FEV<sub>1</sub> measurements were similar across treatments: ADVAIR HFA 115/21, 2.23 L; fluticasone propionate 110 mcg, 2.18 L; salmeterol, 2.22 L; and placebo, 2.17 L.

Efficacy results in this study were similar to those observed in Studies 1 and 2. Patients receiving ADVAIR HFA 115/21 had significantly greater improvements in FEV<sub>1</sub> (0.41 L, 20%) compared with fluticasone propionate 110 mcg (0.19 L, 9%), salmeterol (0.15 L, 8%), and placebo (-0.12 L, -6%). Significantly fewer patients receiving ADVAIR HFA 115/21 were withdrawn from this study for worsening asthma (7%) compared with salmeterol (24%) and placebo (54%). Fewer patients receiving ADVAIR HFA 115/21 were withdrawn due to worsening asthma (7%) compared with fluticasone propionate 110 mcg (11%); however, the difference was not statistically significant.

**Study 4: Clinical Trial With ADVAIR HFA 230/21 Inhalation Aerosol:** This active-controlled, 12-week, non-US study compared ADVAIR HFA 230/21 with fluticasone propionate CFC inhalation aerosol 220 mcg, each given as 2 inhalations twice daily, and with ADVAIR DISKUS 500/50 given as 1 inhalation twice daily in 509 patients using inhaled corticosteroids (daily doses of beclomethasone dipropionate CFC inhalation aerosol 1,500 to 2,000 mcg; budesonide 1,500 to 2,000 mcg; flunisolide 1,500 to 2,000 mcg; fluticasone propionate inhalation aerosol 660 to 880 mcg; or fluticasone propionate inhalation powder 750 to 1,000 mcg). The primary efficacy endpoint was morning PEF.

Baseline morning PEF measurements were similar across treatments: ADVAIR HFA 230/21, 327 L/min; ADVAIR DISKUS 500/50, 341 L/min; and fluticasone propionate 220 mcg, 345 L/min. As shown in Figure 2, morning PEF improved significantly with ADVAIR HFA 230/21 compared with fluticasone propionate 220 mcg over the 12-week treatment period. Improvements in morning PEF observed with ADVAIR HFA 230/21 were similar to improvements observed with ADVAIR DISKUS 500/50.

**Figure 2. Mean Percent Change From Baseline in Morning Peak Expiratory Flow in Patients Previously Treated With Inhaled Corticosteroids (Study 4)**

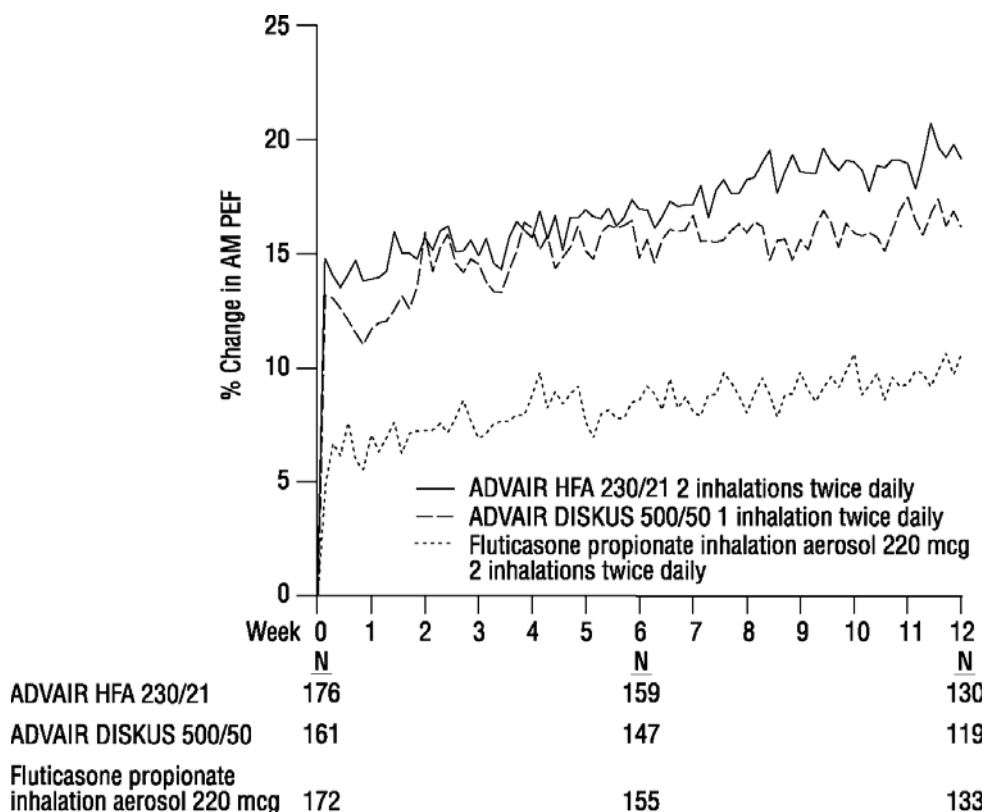

**One-Year Safety Study: Clinical Trial With ADVAIR HFA 45/21, 115/21, and 230/21 Inhalation Aerosol:** This 1-year, open-label, non-US study evaluated the safety of ADVAIR HFA 45/21, 115/21, and 230/21 given as 2 inhalations twice daily in 325 patients. This study was stratified into 3 groups according to baseline asthma therapy: patients using short-acting beta<sub>2</sub>-agonists alone (n = 42), salmeterol (n = 91), or inhaled corticosteroids (n = 277). Patients treated with short-acting beta<sub>2</sub>-agonists alone, salmeterol, or low doses of inhaled corticosteroids with or without concurrent salmeterol received ADVAIR HFA 45/21. Patients treated with moderate doses of inhaled corticosteroids with or without concurrent salmeterol received ADVAIR HFA 115/21. Patients treated with high doses of inhaled corticosteroids with or without concurrent salmeterol received ADVAIR HFA 230/21. Baseline FEV<sub>1</sub> measurements ranged from 2.3 to 2.6 L.

Improvements in FEV<sub>1</sub> (0.17 to 0.35 L at 4 weeks) were seen across all 3 treatments and were sustained throughout the 52-week treatment period. Few patients (3%) were withdrawn due to worsening asthma over 1 year.

**Onset of Action and Progression of Improvement in Asthma Control:** The onset of action and progression of improvement in asthma control were evaluated in 2 placebo-controlled

US trials and 1 active-controlled US trial. Following the first dose, the median time to onset of clinically significant bronchodilatation ( $\geq 15\%$  improvement in FEV<sub>1</sub>) in most patients was seen within 30 to 60 minutes. Maximum improvement in FEV<sub>1</sub> occurred within 4 hours, and clinically significant improvement was maintained for 12 hours (see Figure 3).

Following the initial dose, predose FEV<sub>1</sub> relative to day 1 baseline improved markedly over the first week of treatment and continued to improve over the 12 weeks of treatment in all 3 studies.

No diminution in the 12-hour bronchodilator effect was observed with either ADVAIR HFA 45/21 (Figures 3 and 4) or ADVAIR HFA 230/21 as assessed by FEV<sub>1</sub> following 12 weeks of therapy.

**Figure 3. Percent Change in Serial 12-Hour FEV<sub>1</sub> in Patients Previously Using Either Beta<sub>2</sub>-Agonists (Albuterol or Salmeterol) or Inhaled Corticosteroids (Study 1)**

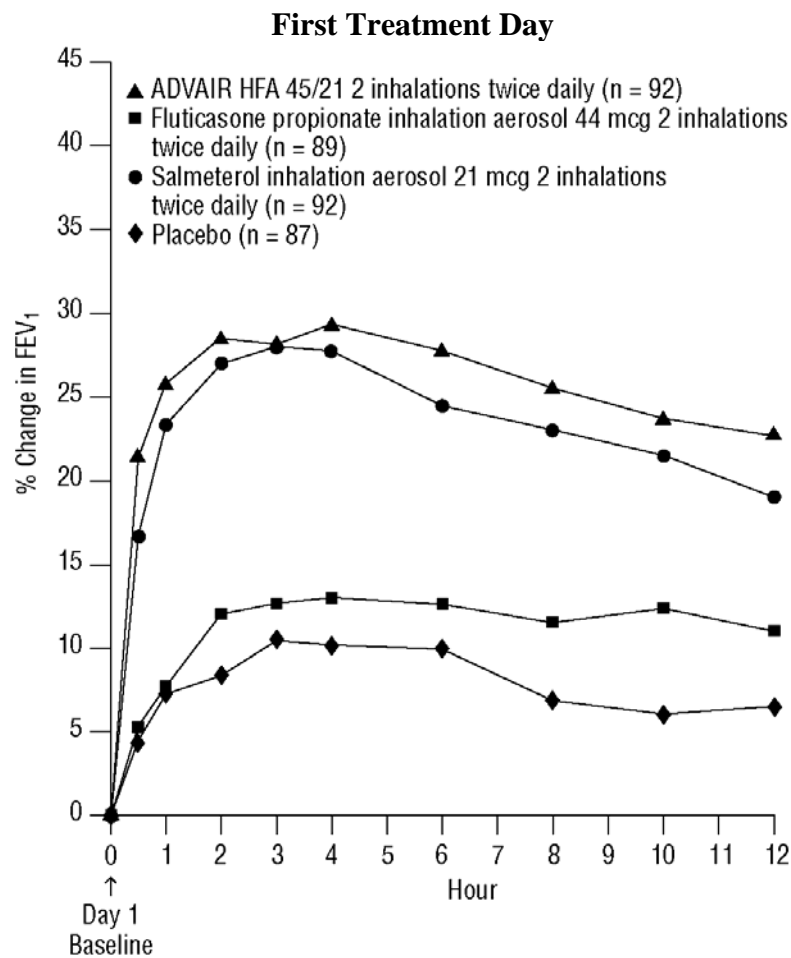

**Figure 4. Percent Change in Serial 12-Hour FEV<sub>1</sub> in Patients Previously Using Either Beta<sub>2</sub>-Agonists (Albuterol or Salmeterol) or Inhaled Corticosteroids (Study 1)**

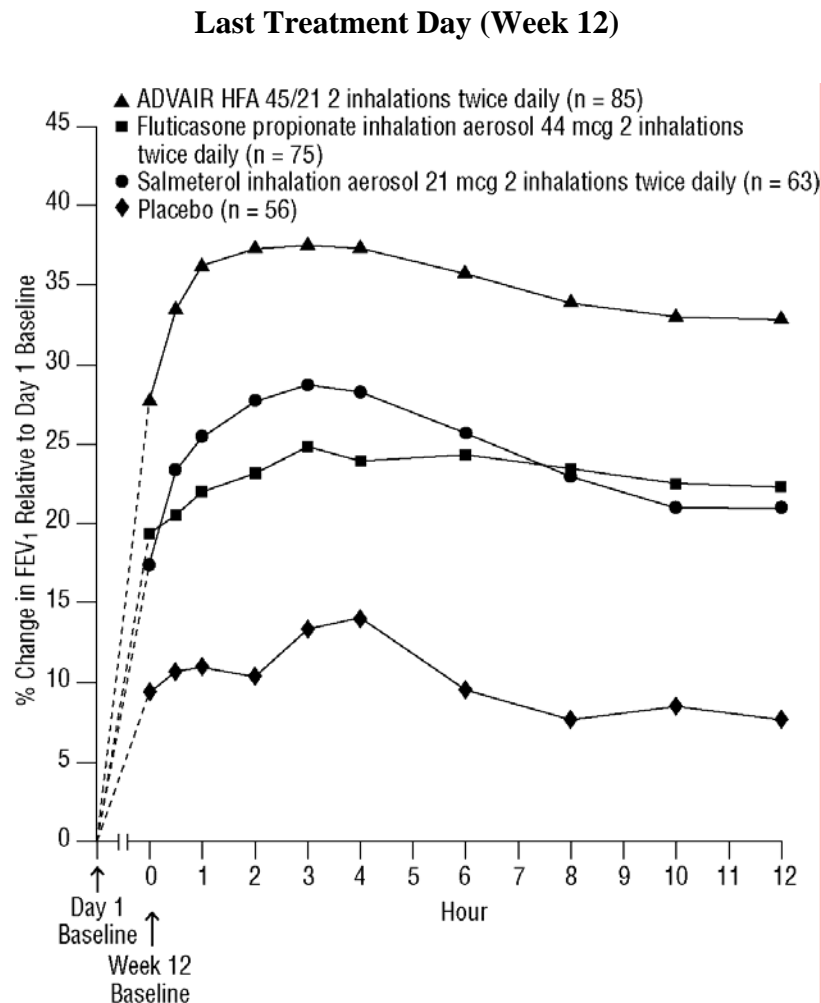

Reduction in asthma symptoms and use of rescue VENTOLIN Inhalation Aerosol and improvement in morning and evening PEF also occurred within the first day of treatment with ADVAIR HFA, and continued to improve over the 12 weeks of therapy in all 3 studies.

## INDICATIONS AND USAGE

ADVAIR HFA is indicated for the long-term, twice-daily maintenance treatment of asthma in patients 12 years of age and older.

Long-acting beta<sub>2</sub>-adrenergic agonists, such as salmeterol, one of the active ingredients in ADVAIR HFA, may increase the risk of asthma-related death (see WARNINGS). Therefore, when treating patients with asthma, physicians should only prescribe ADVAIR HFA for patients not adequately controlled on other asthma-controller medications (e.g., low- to medium-dose inhaled corticosteroids) or whose disease severity clearly warrants initiation of treatment with 2

maintenance therapies. ADVAIR HFA is not indicated in patients whose asthma can be successfully managed by inhaled corticosteroids along with occasional use of inhaled, short-acting beta<sub>2</sub>-agonists.

ADVAIR HFA is NOT indicated for the relief of acute bronchospasm.

## CONTRAINDICATIONS

ADVAIR HFA is contraindicated in the primary treatment of status asthmaticus or other acute episodes of asthma where intensive measures are required.

Hypersensitivity to any of the ingredients of these preparations contraindicates their use.

## WARNINGS

**Long-acting beta<sub>2</sub>-adrenergic agonists, such as salmeterol, one of the active ingredients in ADVAIR HFA, may increase the risk of asthma-related death. Therefore, when treating patients with asthma, physicians should only prescribe ADVAIR HFA for patients not adequately controlled on other asthma-controller medications (e.g., low- to medium-dose inhaled corticosteroids) or whose disease severity clearly warrants initiation of treatment with 2 maintenance therapies.**

A large placebo-controlled US study that compared the safety of salmeterol with placebo, each added to usual asthma therapy, showed an increase in asthma-related deaths in patients receiving salmeterol. The Salmeterol Multi-center Asthma Research Trial (SMART) was a randomized, double-blind study that enrolled long-acting beta<sub>2</sub>-agonist-naïve patients with asthma to assess the safety of salmeterol (SEREVENT Inhalation Aerosol) 42 mcg twice daily over 28 weeks compared with placebo when added to usual asthma therapy. A planned interim analysis was conducted when approximately half of the intended number of patients had been enrolled (N = 26,355), which led to premature termination of the study. The results of the interim analysis showed that patients receiving salmeterol were at increased risk for fatal asthma events (see Table 3 and Figure 5). In the total population, a higher rate of asthma-related death occurred in patients treated with salmeterol than those treated with placebo (0.10% vs. 0.02%; relative risk 4.37 [95% CI 1.25, 15.34]).

Post-hoc subpopulation analyses were performed. In Caucasians, asthma-related death occurred at a higher rate in patients treated with salmeterol than in patients treated with placebo (0.07% vs. 0.01%; relative risk 5.82 [95% CI 0.70, 48.37]). In African Americans also, asthma-related death occurred at a higher rate in patients treated with salmeterol than those treated with placebo (0.31% vs. 0.04%; relative risk 7.26 [95% CI 0.89, 58.94]). Although the relative risks of asthma-related death were similar in Caucasians and African Americans, the estimate of excess deaths in patients treated with salmeterol was greater in African Americans because there was a higher overall rate of asthma-related death in African American patients (see Table 3). Given the similar basic mechanisms of action of beta<sub>2</sub>-agonists, it is possible that the findings seen in the SMART study represent a class effect.

The data from the SMART study are not adequate to determine whether concurrent use of inhaled corticosteroids, such as fluticasone propionate, the other active ingredient in ADVAIR HFA, or other asthma-controller therapy modifies the risk of asthma-related death.

**Table 3: Asthma-Related Deaths in the 28-Week Salmeterol Multi-center Asthma Research Trial (SMART)**

	Salmeterol n (% <sup>*</sup> )	Placebo n (% <sup>*</sup> )	Relative Risk <sup>†</sup> (95% Confidence Interval)	Excess Deaths Expressed per 10,000 Patients <sup>‡</sup> (95% Confidence Interval)
<b>Total Population<sup>§</sup></b> Salmeterol: N = 13,176 Placebo: N = 13,179	13 (0.10%)	3 (0.02%)	4.37 (1.25, 15.34)	8 (3, 13)
<b>Caucasian</b> Salmeterol: N = 9,281 Placebo: N = 9,361	6 (0.07%)	1 (0.01%)	5.82 (0.70, 48.37)	6 (1, 10)
<b>African American</b> Salmeterol: N = 2,366 Placebo: N = 2,319	7 (0.31%)	1 (0.04%)	7.26 (0.89, 58.94)	27 (8, 46)

\* Life-table 28-week estimate, adjusted according to the patients' actual lengths of exposure to study treatment to account for early withdrawal of patients from the study.

† Relative risk is the ratio of the rate of asthma-related death in the salmeterol group and the rate in the placebo group. The relative risk indicates how many more times likely an asthma-related death occurred in the salmeterol group than in the placebo group in a 28-week treatment period.

‡ Estimate of the number of additional asthma-related deaths in patients treated with salmeterol in SMART, assuming 10,000 patients received salmeterol for a 28-week treatment period. Estimate calculated as the difference between the salmeterol and placebo groups in the rates of asthma-related death multiplied by 10,000.

§ The Total Population includes the following ethnic origins listed on the case report form: Caucasian, African American, Hispanic, Asian, and "Other." In addition, the Total Population includes those patients whose ethnic origin was not reported. The results for Caucasian and African American subpopulations are shown above. No asthma-related deaths occurred in the Hispanic (salmeterol n = 996, placebo n = 999), Asian (salmeterol n = 173, placebo n = 149), or "Other" (salmeterol n = 230, placebo n = 224) subpopulations. One asthma-related death occurred in the placebo group in the subpopulation whose ethnic origin was not reported (salmeterol n = 130, placebo n = 127).

**Figure 5. Cumulative Incidence of Asthma-Related Deaths in the 28-Week Salmeterol Multi-center Asthma Research Trial (SMART), by Duration of Treatment**

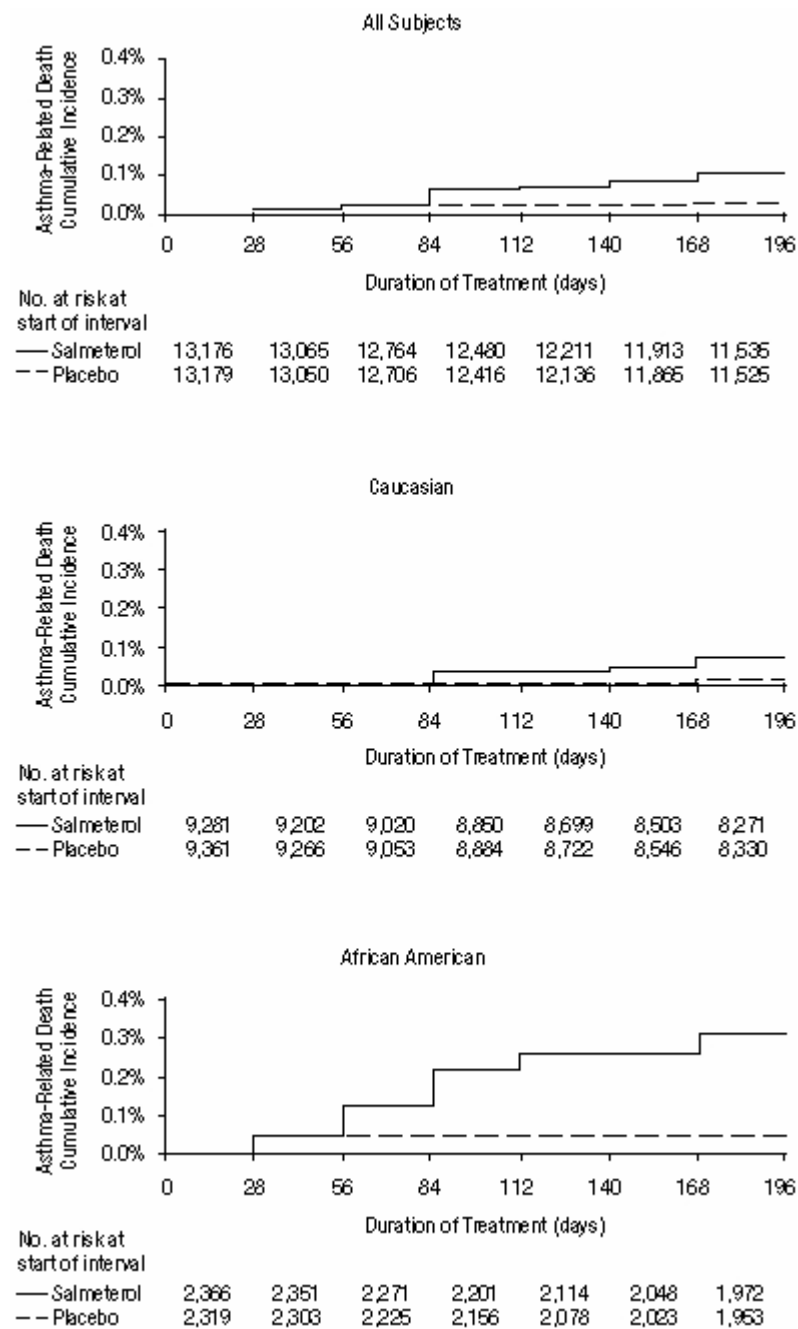

A 16-week clinical study performed in the United Kingdom, the Salmeterol Nationwide Surveillance (SNS) study, showed results similar to the SMART study. In the SNS study, the rate of asthma-related death was numerically, though not statistically significantly, greater in patients

with asthma treated with salmeterol (42 mcg twice daily) than those treated with albuterol (180 mcg 4 times daily) added to usual asthma therapy.

**The following additional WARNINGS about ADVAIR HFA should be noted.**

1. ADVAIR HFA should not be initiated in patients during rapidly deteriorating or potentially life-threatening episodes of asthma. Serious acute respiratory events, including fatalities, have been reported both in the United States and worldwide when salmeterol, a component of ADVAIR HFA, has been initiated in patients with significantly worsening or acutely deteriorating asthma. In most cases, these have occurred in patients with severe asthma (e.g., patients with a history of corticosteroid dependence, low pulmonary function, intubation, mechanical ventilation, frequent hospitalizations, or previous life-threatening acute asthma exacerbations) and/or in some patients in whom asthma has been acutely deteriorating (e.g., unresponsive to usual medications; increasing need for inhaled, short-acting beta<sub>2</sub>-agonists; increasing need for systemic corticosteroids; significant increase in symptoms; recent emergency room visits; sudden or progressive deterioration in pulmonary function). However, they have occurred in a few patients with less severe asthma as well. It was not possible from these reports to determine whether salmeterol contributed to these events.

2. ADVAIR HFA should not be used to treat acute symptoms. An inhaled, short-acting beta<sub>2</sub>-agonist, not ADVAIR HFA, should be used to relieve acute symptoms of shortness of breath. When prescribing ADVAIR HFA, the physician must also provide the patient with an inhaled, short-acting beta<sub>2</sub>-agonist (e.g., albuterol) for treatment of shortness of breath that occurs acutely, despite regular twice-daily (morning and evening) use of ADVAIR HFA.

When beginning treatment with ADVAIR HFA, patients who have been taking oral or inhaled, short-acting beta<sub>2</sub>-agonists on a regular basis (e.g., 4 times a day) should be instructed to discontinue the regular use of these drugs. For patients taking ADVAIR HFA, inhaled, short-acting beta<sub>2</sub>-agonists should only be used for symptomatic relief of acute symptoms of shortness of breath (see PRECAUTIONS: Information for Patients).

3. Increasing use of inhaled, short-acting beta<sub>2</sub>-agonists is a marker of deteriorating asthma. The physician and patient should be alert to such changes. The patient's condition may deteriorate acutely over a period of hours or chronically over several days or longer. If the patient's inhaled, short-acting beta<sub>2</sub>-agonist becomes less effective, the patient needs more inhalations than usual, or the patient develops a significant decrease in lung function, this may be a marker of destabilization of the disease. In this setting, the patient requires immediate reevaluation with reassessment of the treatment regimen, giving special consideration to the possible need for replacing the current strength of ADVAIR HFA with a higher strength, adding additional inhaled corticosteroid, or initiating systemic corticosteroids. Patients should not use more than 2 inhalations twice daily (morning and evening) of ADVAIR HFA.

4. ADVAIR HFA should not be used for transferring patients from systemic corticosteroid therapy. Particular care is needed for patients who have been transferred from systemically active corticosteroids to inhaled corticosteroids because deaths due to adrenal insufficiency have occurred in patients with asthma during and after transfer from systemic corticosteroids to less

systemically available inhaled corticosteroids. After withdrawal from systemic corticosteroids, a number of months are required for recovery of HPA function.

Patients who have been previously maintained on 20 mg or more per day of prednisone (or its equivalent) may be most susceptible, particularly when their systemic corticosteroids have been almost completely withdrawn. During this period of HPA suppression, patients may exhibit signs and symptoms of adrenal insufficiency when exposed to trauma, surgery, or infection (particularly gastroenteritis) or other conditions associated with severe electrolyte loss. Although inhaled corticosteroids may provide control of asthma symptoms during these episodes, in recommended doses they supply less than normal physiologic amounts of glucocorticoid (cortisol) systemically and do NOT provide the mineralocorticoid activity that is necessary for coping with these emergencies.

During periods of stress or a severe asthma attack, patients who have been withdrawn from systemic corticosteroids should be instructed to resume oral corticosteroids (in large doses) immediately and to contact their physicians for further instruction. These patients should also be instructed to carry a warning card indicating that they may need supplementary systemic corticosteroids during periods of stress or a severe asthma attack.

5. ADVAIR HFA should not be used in conjunction with an inhaled, long-acting beta<sub>2</sub>-agonist.

Patients who are receiving ADVAIR HFA twice daily should not use additional salmeterol or other long-acting beta<sub>2</sub>-agonists (e.g., formoterol) for prevention of exercise-induced bronchospasm (EIB) or the maintenance treatment of asthma. Additional benefit would not be gained from using supplemental salmeterol or formoterol for prevention of EIB since ADVAIR HFA already contains an inhaled, long-acting beta<sub>2</sub>-agonist.

6. The recommended dosage should not be exceeded. ADVAIR HFA should not be used more often or at higher doses than recommended. Fatalities have been reported in association with excessive use of inhaled sympathomimetic drugs. Large doses of inhaled or oral salmeterol (12 to 20 times the recommended dose) have been associated with clinically significant prolongation of the QTc interval, which has the potential for producing ventricular arrhythmias.

7. Paradoxical bronchospasm. As with other inhaled asthma medications, ADVAIR HFA can produce paradoxical bronchospasm, which may be life threatening. If paradoxical bronchospasm occurs following dosing with ADVAIR HFA, it should be treated immediately with an inhaled, short-acting bronchodilator; ADVAIR HFA should be discontinued immediately; and alternative therapy should be instituted.

8. Immediate hypersensitivity reactions. Immediate hypersensitivity reactions may occur after administration of ADVAIR HFA, as demonstrated by cases of urticaria, angioedema, rash, and bronchospasm.

9. Upper airway symptoms. Symptoms of laryngeal spasm, irritation, or swelling, such as stridor and choking, have been reported in patients receiving fluticasone propionate and salmeterol, components of ADVAIR HFA.

10. Cardiovascular disorders. ADVAIR HFA, like all products containing sympathomimetic amines, should be used with caution in patients with cardiovascular disorders, especially

coronary insufficiency, cardiac arrhythmias, and hypertension. Salmeterol, a component of ADVAIR HFA, can produce a clinically significant cardiovascular effect in some patients as measured by pulse rate, blood pressure, and/or symptoms. Although such effects are uncommon after administration of salmeterol at recommended doses, if they occur, the drug may need to be discontinued. In addition, beta-agonists have been reported to produce electrocardiogram (ECG) changes, such as flattening of the T wave, prolongation of the QTc interval, and ST segment depression. The clinical significance of these findings is unknown.

11. Discontinuation of systemic corticosteroids. Transfer of patients from systemic corticosteroid therapy to ADVAIR HFA may unmask conditions previously suppressed by the systemic corticosteroid therapy, e.g., rhinitis, conjunctivitis, eczema, arthritis, and eosinophilic conditions.

12. Immunosuppression. Persons who are using drugs that suppress the immune system are more susceptible to infections than healthy individuals. Chickenpox and measles, for example, can have a more serious or even fatal course in susceptible children or adults using corticosteroids. In such children or adults who have not had these diseases or been properly immunized, particular care should be taken to avoid exposure. How the dose, route, and duration of corticosteroid administration affect the risk of developing a disseminated infection is not known. The contribution of the underlying disease and/or prior corticosteroid treatment to the risk is also not known. If exposed to chickenpox, prophylaxis with varicella zoster immune globulin (VZIG) may be indicated. If exposed to measles, prophylaxis with pooled intramuscular immunoglobulin (IG) may be indicated. (See the respective package inserts for complete VZIG and IG prescribing information.) If chickenpox develops, treatment with antiviral agents may be considered.

13. Pneumonia. Lower respiratory tract infections, including pneumonia, have been reported in patients with COPD following the inhaled administration of corticosteroids, including fluticasone propionate and ADVAIR DISKUS. In 2 replicate 12-month studies of 1,579 patients with COPD, there was a higher incidence of pneumonia reported in patients receiving ADVAIR DISKUS 250/50 (7%) than in those receiving salmeterol 50 mcg (3%). The incidence of pneumonia in the patients treated with ADVAIR DISKUS was higher in patients over 65 years of age (9%) compared with the incidence in patients less than 65 years of age (4%).

In a 3-year study of 6,184 patients with COPD, there was a higher incidence of pneumonia reported in patients receiving ADVAIR DISKUS 500/50 compared with placebo (16% with ADVAIR DISKUS 500/50, 14% with fluticasone propionate 500 mcg, 11% with salmeterol 50 mcg, and 9% with placebo). Similar to what was seen in the 1-year studies with ADVAIR DISKUS 250/50, the incidence of pneumonia was higher in patients over 65 years of age (18% with ADVAIR DISKUS 500/50 versus 10% with placebo) compared with patients less than 65 years of age (14% with ADVAIR DISKUS 500/50 versus 8% with placebo).

14. Potential drug interactions with CYP 3A4 inhibitors. Both fluticasone propionate and salmeterol are substrates of CYP 3A4.

Fluticasone Propionate: A drug interaction study in healthy subjects has shown that ritonavir (a strong cytochrome P450 3A4 inhibitor) can significantly increase systemic fluticasone propionate exposure (AUC), resulting in significantly reduced serum cortisol concentrations (see

CLINICAL PHARMACOLOGY: Pharmacokinetics: *Fluticasone Propionate: Drug Interactions* and PRECAUTIONS: Drug Interactions: *Inhibitors of Cytochrome P450*). During postmarketing use, there have been reports of clinically significant drug interactions in patients receiving fluticasone propionate and ritonavir, resulting in systemic corticosteroid effects including Cushing syndrome and adrenal suppression. Therefore, coadministration of fluticasone propionate and ritonavir is not recommended unless the potential benefit to the patient outweighs the risk of systemic corticosteroid side effects.

Salmeterol: Because of the potential for drug interactions and the potential for increased risk of cardiovascular adverse events, the concomitant use of ADVAIR HFA with strong CYP 3A4 inhibitors (e.g., ketoconazole, ritonavir, atazanavir, clarithromycin, indinavir, itraconazole, nefazodone, nelfinavir, saquinavir, telithromycin) is not recommended (see CLINICAL PHARMACOLOGY: Pharmacokinetics: *Salmeterol Xinafoate: Drug Interactions*).

## PRECAUTIONS

**General: Cardiovascular Effects:** Cardiovascular and central nervous system effects seen with all sympathomimetic drugs (e.g., increased blood pressure, heart rate, excitement) can occur after use of salmeterol, a component of ADVAIR HFA, and may require discontinuation of ADVAIR HFA. ADVAIR HFA, like all medications containing sympathomimetic amines, should be used with caution in patients with cardiovascular disorders, especially coronary insufficiency, cardiac arrhythmias, and hypertension; in patients with convulsive disorders or thyrotoxicosis; and in patients who are unusually responsive to sympathomimetic amines.

As has been described with other beta-adrenergic agonist bronchodilators, clinically significant changes in ECGs have been seen infrequently in individual patients in controlled clinical studies with ADVAIR HFA and salmeterol. Clinically significant changes in systolic and/or diastolic blood pressure and pulse rate have been seen infrequently in individual patients in controlled clinical studies with salmeterol, a component of ADVAIR HFA.

**Metabolic and Other Effects:** Long-term use of orally inhaled corticosteroids may affect normal bone metabolism, resulting in a loss of bone mineral density. In patients with major risk factors for decreased bone mineral content, such as tobacco use, advanced age, sedentary lifestyle, poor nutrition, family history of osteoporosis, or chronic use of drugs that can reduce bone mass (e.g., anticonvulsants and corticosteroids), ADVAIR HFA may pose an additional risk.

Doses of the related beta<sub>2</sub>-adrenoceptor agonist albuterol, when administered intravenously, have been reported to aggravate preexisting diabetes mellitus and ketoacidosis. Beta-adrenergic agonist medications may produce significant hypokalemia in some patients, possibly through intracellular shunting, which has the potential to produce adverse cardiovascular effects. The decrease in serum potassium is usually transient, not requiring supplementation.

Clinically significant changes in blood glucose and/or serum potassium were seen infrequently during clinical studies with ADVAIR HFA at recommended doses.

During withdrawal from oral corticosteroids, some patients may experience symptoms of systemically active corticosteroid withdrawal, e.g., joint and/or muscular pain, lassitude, and depression, despite maintenance or even improvement of respiratory function.

Fluticasone propionate, a component of ADVAIR HFA, will often help control asthma symptoms with less suppression of HPA function than therapeutically equivalent oral doses of prednisone. Since fluticasone propionate is absorbed into the circulation and can be systemically active at higher doses, the beneficial effects of ADVAIR HFA in minimizing HPA dysfunction may be expected only when recommended dosages are not exceeded and individual patients are titrated to the lowest effective dose. A relationship between plasma levels of fluticasone propionate and inhibitory effects on stimulated cortisol production has been shown after 4 weeks of treatment with fluticasone propionate inhalation aerosol. Since individual sensitivity to effects on cortisol production exists, physicians should consider this information when prescribing ADVAIR HFA.

Because of the possibility of systemic absorption of inhaled corticosteroids, patients treated with ADVAIR HFA should be observed carefully for any evidence of systemic corticosteroid effects. Particular care should be taken in observing patients postoperatively or during periods of stress for evidence of inadequate adrenal response.

It is possible that systemic corticosteroid effects such as hypercorticism and adrenal suppression (including adrenal crisis) may appear in a small number of patients, particularly when fluticasone propionate is administered at higher than recommended doses over prolonged periods of time. If such effects occur, the dosage of ADVAIR HFA should be reduced slowly, consistent with accepted procedures for reducing systemic corticosteroids and for management of asthma.

A reduction of growth velocity in children and adolescents may occur as a result of poorly controlled asthma or from the therapeutic use of corticosteroids, including inhaled corticosteroids (see PRECAUTIONS: Pediatric Use). The effects of long-term treatment of children and adolescents with inhaled corticosteroids, including fluticasone propionate, on final adult height are not known. Patients should be maintained on the lowest strength of ADVAIR HFA that effectively controls their asthma.

The long-term effects of ADVAIR HFA in human subjects are not fully known. In particular, the effects resulting from chronic use of fluticasone propionate on developmental or immunologic processes in the mouth, pharynx, trachea, and lung are unknown. Some patients received inhaled fluticasone propionate on a continuous basis in a clinical study for up to 4 years. In clinical studies with patients treated for 2 years with inhaled fluticasone propionate, no apparent differences in the type or severity of adverse reactions were observed after long- versus short-term treatment.

Glaucoma, increased intraocular pressure, and cataracts have been reported in patients following the long-term administration of inhaled corticosteroids, including fluticasone propionate, a component of ADVAIR HFA.

Lower respiratory tract infections, including pneumonia, have been reported following the inhaled administration of corticosteroids, including fluticasone propionate, a component of ADVAIR HFA.

In clinical studies with ADVAIR HFA, the development of localized infections of the pharynx with *Candida albicans* has occurred. When such an infection develops, it should be treated with appropriate local or systemic (i.e., oral antifungal) therapy while remaining on treatment with ADVAIR HFA, but at times therapy with ADVAIR HFA may need to be interrupted.

Inhaled corticosteroids should be used with caution, if at all, in patients with active or quiescent tuberculosis infections of the respiratory tract; untreated systemic fungal, bacterial, viral, or parasitic infections; or ocular herpes simplex.

***Eosinophilic Conditions:*** In rare cases, patients on inhaled fluticasone propionate, a component of ADVAIR HFA, may present with systemic eosinophilic conditions, with some patients presenting with clinical features of vasculitis consistent with Churg-Strauss syndrome, a condition that is often treated with systemic corticosteroid therapy. These events usually, but not always, have been associated with the reduction and/or withdrawal of oral corticosteroid therapy following the introduction of fluticasone propionate. Cases of serious eosinophilic conditions have also been reported with other inhaled corticosteroids in this clinical setting. Physicians should be alert to eosinophilia, vasculitic rash, worsening pulmonary symptoms, cardiac complications, and/or neuropathy presenting in their patients. A causal relationship between fluticasone propionate and these underlying conditions has not been established (see ADVERSE REACTIONS: Observed During Clinical Practice: *Eosinophilic Conditions*).

**Information for Patients: Patients should be instructed to read the accompanying Medication Guide with each new prescription and refill. The complete text of the Medication Guide is reprinted at the end of this document.**

Patients being treated with ADVAIR HFA should receive the following information and instructions. This information is intended to aid them in the safe and effective use of this medication. It is not a disclosure of all possible adverse or intended effects. It is important that patients understand how to use ADVAIR HFA in relation to other asthma medications they are taking.

1. **Patients should be informed that salmeterol, one of the active ingredients in ADVAIR HFA, may increase the risk of asthma-related death.** They should also be informed that data are not adequate to determine whether the concurrent use of inhaled corticosteroids, such as fluticasone propionate, the other component of ADVAIR HFA, or other asthma-controller therapy modifies this risk.
2. ADVAIR HFA is not meant to relieve acute asthma symptoms and extra doses should not be used for that purpose. Acute symptoms should be treated with an inhaled, short-acting beta<sub>2</sub>-agonist such as albuterol (the physician should provide the patient with such medication and instruct the patient in how it should be used).
3. The physician should be notified immediately if any of the following signs of seriously worsening asthma occur:

- decreasing effectiveness of inhaled, short-acting beta<sub>2</sub>-agonists;
  - need for more inhalations than usual of inhaled, short-acting beta<sub>2</sub>-agonists;
  - significant decrease in lung function as outlined by the physician.
4. Patients should not stop therapy with ADVAIR HFA without physician/provider guidance since symptoms may recur after discontinuation.
  5. Patients should be cautioned regarding common adverse effects associated with beta<sub>2</sub>-agonists, such as palpitations, chest pain, rapid heart rate, tremor, or nervousness.
  6. Long-term use of inhaled corticosteroids, including fluticasone propionate, a component of ADVAIR HFA, may increase the risk of some eye problems (cataracts or glaucoma). Regular eye examinations should be considered.
  7. When patients are prescribed ADVAIR HFA, other medications for asthma should be used only as directed by the physician.
  8. Patients who are pregnant or nursing should contact the physician about the use of ADVAIR HFA.
  9. Patients should use ADVAIR HFA at regular intervals as directed. Results of clinical trials indicated significant improvement may occur within the first 30 minutes of taking the first dose; however, the full benefit may not be achieved until treatment has been administered for 1 week or longer. The patient should not use more than the prescribed dosage but should contact the physician if symptoms do not improve or if the condition worsens.
  10. The bronchodilation from a single dose of ADVAIR HFA may last up to 12 hours or longer. The recommended dosage (2 inhalations twice daily, morning and evening) should not be exceeded. Patients who are receiving ADVAIR HFA twice daily should not use salmeterol or other inhaled, long-acting beta<sub>2</sub>-agonists (e.g., formoterol) for prevention of EIB or maintenance treatment of asthma.
  11. Patients should be warned to avoid exposure to chickenpox or measles and, if they are exposed to consult the physician without delay.
  12. Prime the inhaler before using for the first time by releasing 4 test sprays into the air away from the face, shaking well for 5 seconds before each spray. In cases where the inhaler has not been used for more than 4 weeks or when it has been dropped, prime the inhaler again by releasing 2 test sprays into the air away from the face, shaking well for 5 seconds before each spray.
  13. After inhalation, rinse the mouth with water and spit out. Do not swallow.
  14. Clean the inhaler at least once a week after the evening dose. Keeping the canister and plastic actuator clean is important to prevent medicine buildup. (See the cleaning instructions in the “How to use your ADVAIR HFA” section of the Medication Guide accompanying the product.)
  15. Use ADVAIR HFA only with the actuator supplied with the product. When the counter reads 020, contact the pharmacist for a refill of medication or consult the physician to determine whether a prescription refill is needed. Discard the inhaler when the counter reads 000. Never try to alter the numbers or remove the counter from the metal canister.

16. For important summary information and instructions for the proper use of ADVAIR HFA, the patient should carefully read and follow the Medication Guide accompanying the product.

**Drug Interactions:** ADVAIR HFA has been used concomitantly with other drugs, including short-acting beta<sub>2</sub>-agonists, methylxanthines, and intranasal corticosteroids, commonly used in patients with asthma, without adverse drug reactions. No formal drug interaction studies have been performed with ADVAIR HFA.

**Short-Acting Beta<sub>2</sub>-Agonists:** In three 12-week US clinical trials, the mean daily need for additional beta<sub>2</sub>-agonist use in 277 patients receiving ADVAIR HFA was approximately 1.2 inhalations/day and ranged from 0 to 9 inhalations/day. Two percent (2%) of patients receiving ADVAIR HFA in these trials averaged 6 or more inhalations per day over the course of the 12-week trials. No increase in frequency of cardiovascular events was observed among patients who averaged 6 or more inhalations per day.

**Methylxanthines:** The concurrent use of intravenously or orally administered methylxanthines (e.g., aminophylline, theophylline) by patients receiving ADVAIR HFA has not been completely evaluated. In five 12-week clinical trials (3 US and 2 non-US), 45 patients receiving ADVAIR HFA 45/21, 115/21, or 230/21 twice daily concurrently with a theophylline product had adverse event rates similar to those in 577 patients receiving ADVAIR HFA without theophylline.

**Fluticasone Propionate Nasal Spray:** In patients receiving ADVAIR HFA in three 12-week US clinical trials, no difference in the profile of adverse events or HPA axis effects was noted between patients receiving FLONASE<sup>®</sup> (fluticasone propionate) Nasal Spray, 50 mcg concurrently (n = 89) and those who were not (n = 192).

**Monoamine Oxidase Inhibitors and Tricyclic Antidepressants:** ADVAIR HFA should be administered with extreme caution to patients being treated with monoamine oxidase inhibitors or tricyclic antidepressants, or within 2 weeks of discontinuation of such agents, because the action of salmeterol, a component of ADVAIR HFA, on the vascular system may be potentiated by these agents.

**Beta-Adrenergic Receptor Blocking Agents:** Beta-blockers not only block the pulmonary effect of beta-agonists, such as salmeterol, a component of ADVAIR HFA, but may produce severe bronchospasm in patients with asthma. Therefore, patients with asthma should not normally be treated with beta-blockers. However, under certain circumstances, there may be no acceptable alternatives to the use of beta-adrenergic blocking agents in patients with asthma. In this setting, cardioselective beta-blockers could be considered, although they should be administered with caution.

**Diuretics:** The ECG changes and/or hypokalemia that may result from the administration of nonpotassium-sparing diuretics (such as loop or thiazide diuretics) can be acutely worsened by beta-agonists, especially when the recommended dose of the beta-agonist is exceeded. Although the clinical significance of these effects is not known, caution is advised in the coadministration of beta-agonists with nonpotassium-sparing diuretics.

**Inhibitors of Cytochrome P450:** Fluticasone propionate and salmeterol are substrates of cytochrome P450 3A4.

**Fluticasone propionate:** A drug interaction study with fluticasone propionate aqueous nasal spray in healthy subjects has shown that ritonavir (a strong cytochrome P450 3A4 inhibitor) can significantly increase plasma fluticasone propionate exposure, resulting in significantly reduced serum cortisol concentrations (see CLINICAL PHARMACOLOGY: Pharmacokinetics: *Fluticasone Propionate: Drug Interactions*). During postmarketing use, there have been reports of clinically significant drug interactions in patients receiving fluticasone propionate and ritonavir, resulting in systemic corticosteroid effects including Cushing's syndrome and adrenal suppression. Therefore, coadministration of fluticasone propionate and ritonavir is not recommended unless the potential benefit to the patient outweighs the risk of systemic corticosteroid side effects.

In a placebo-controlled, crossover study in 8 healthy adult volunteers, coadministration of a single dose of orally inhaled fluticasone propionate (1,000 mcg) with multiple doses of ketoconazole (200 mg) to steady state resulted in increased systemic fluticasone propionate exposure, a reduction in plasma cortisol AUC, and no effect on urinary excretion of cortisol.

**Salmeterol:** In a drug interaction study in 20 healthy subjects, coadministration of inhaled salmeterol (50 mcg twice daily) and oral ketoconazole (400 mg once daily) for 7 days resulted in greater systemic exposure to salmeterol (AUC increased 16-fold and  $C_{max}$  increased 1.4-fold). Three (3) subjects were withdrawn due to beta<sub>2</sub>-agonist side effects (2 with prolonged QTc and 1 with palpitations and sinus tachycardia). Although there was no statistical effect on the mean QTc, coadministration of salmeterol and ketoconazole was associated with more frequent increases in QTc duration compared with salmeterol and placebo administration. Due to the potential increased risk of cardiovascular adverse events, the concomitant use of salmeterol with strong CYP3A4 inhibitors (e.g., ketoconazole, ritonavir, atazanavir, clarithromycin, indinavir, itraconazole, nefazodone, nelfinavir, saquinavir, telithromycin) is not recommended (see CLINICAL PHARMACOLOGY: Pharmacokinetics: *Salmeterol Xinafoate: Drug Interactions*).

**Carcinogenesis, Mutagenesis, Impairment of Fertility: Fluticasone Propionate:** Fluticasone propionate demonstrated no tumorigenic potential in mice at oral doses up to 1,000 mcg/kg (approximately 4 times the maximum recommended human daily inhalation dose on a mcg/m<sup>2</sup> basis) for 78 weeks or in rats at inhalation doses up to 57 mcg/kg (less than the maximum recommended human daily inhalation dose on a mcg/m<sup>2</sup> basis) for 104 weeks.

Fluticasone propionate did not induce gene mutation in prokaryotic or eukaryotic cells in vitro. No significant clastogenic effect was seen in cultured human peripheral lymphocytes in vitro or in the mouse micronucleus test.

No evidence of impairment of fertility was observed in reproductive studies conducted in male and female rats at subcutaneous doses up to 50 mcg/kg (less than the maximum recommended human daily inhalation dose on a mcg/m<sup>2</sup> basis). Prostate weight was significantly reduced at a subcutaneous dose of 50 mcg/kg.

**Salmeterol:** In an 18-month oral carcinogenicity study in CD-mice, salmeterol at oral doses of 1.4 mg/kg and above (approximately 10 times the maximum recommended human daily inhalation dose based on comparison of the AUCs) caused a dose-related increase in the incidence of smooth muscle hyperplasia, cystic glandular hyperplasia, leiomyomas of the uterus, and ovarian cysts. The incidence of leiomyosarcomas was not statistically significant. No tumors were seen at 0.2 mg/kg (approximately 2 times the maximum recommended human daily inhalation dose in adults based on comparison of the AUCs).

In a 24-month oral and inhalation carcinogenicity study in Sprague Dawley rats, salmeterol caused a dose-related increase in the incidence of mesovarian leiomyomas and ovarian cysts at doses of 0.68 mg/kg and above (approximately 65 times the maximum recommended human daily inhalation dose on a mg/m<sup>2</sup> basis). No tumors were seen at 0.21 mg/kg (approximately 20 times the maximum recommended human daily inhalation dose on a mg/m<sup>2</sup> basis). These findings in rodents are similar to those reported previously for other beta-adrenergic agonist drugs. The relevance of these findings to human use is unknown.

Salmeterol produced no detectable or reproducible increases in microbial and mammalian gene mutation in vitro. No clastogenic activity occurred in vitro in human lymphocytes or in vivo in a rat micronucleus test. No effects on fertility were identified in male and female rats treated with salmeterol at oral doses up to 2 mg/kg (approximately 190 times the maximum recommended human daily inhalation dose on a mg/m<sup>2</sup> basis).

**Pregnancy: Teratogenic Effects: ADVAIR HFA Inhalation Aerosol:** Pregnancy Category C. From the reproduction toxicity studies in mice and rats, no evidence of enhanced toxicity was seen using combinations of fluticasone propionate and salmeterol compared with toxicity data from the components administered separately. In mice combining 150 mcg/kg subcutaneously of fluticasone propionate (less than the maximum recommended human daily inhalation dose on a mcg/m<sup>2</sup> basis) with 10 mg/kg orally of salmeterol (approximately 480 times the maximum recommended human daily inhalation dose on a mg/m<sup>2</sup> basis) were teratogenic. Cleft palate, fetal death, increased implantation loss and delayed ossification was seen. These observations are characteristic of glucocorticoids. No developmental toxicity was observed at combination doses up to 40 mcg/kg subcutaneously of fluticasone propionate (less than the maximum recommended human daily inhalation dose on a mcg/m<sup>2</sup> basis) and up to 1.4 mg/kg orally of salmeterol (approximately 70 times the maximum recommended human daily inhalation dose on a mg/m<sup>2</sup> basis). In rats, no teratogenicity was observed at combination doses up to 30 mcg/kg subcutaneously of fluticasone propionate (less than the maximum recommended human daily inhalation dose on a mcg/m<sup>2</sup> basis) and up to 1 mg/kg of salmeterol (approximately 95 times the maximum recommended human daily inhalation dose on a mg/m<sup>2</sup> basis). Combining 100 mcg/kg subcutaneously of fluticasone propionate (equivalent to the maximum recommended human daily inhalation dose on a mcg/m<sup>2</sup> basis) with 10 mg/kg orally of salmeterol (approximately 970 times the maximum recommended human daily inhalation dose on a mg/m<sup>2</sup> basis) produced maternal toxicity, decreased placental weight, decreased fetal weight, umbilical hernia, delayed ossification, and changes in the occipital bone.

There are no adequate and well-controlled studies with ADVAIR HFA in pregnant women. ADVAIR HFA should be used during pregnancy only if the potential benefit justifies the potential risk to the fetus.

**Fluticasone Propionate:** Pregnancy Category C. Subcutaneous studies in the mouse and rat at 45 and 100 mcg/kg, respectively (less than and equivalent to, respectively, the maximum recommended human daily inhalation dose on a mcg/m<sup>2</sup> basis), revealed fetal toxicity characteristic of potent corticosteroid compounds, including embryonic growth retardation, omphalocele, cleft palate, and retarded cranial ossification. No teratogenicity was seen in the rat at inhalation doses up to 68.7 mcg/kg (less than the maximum recommended human daily inhalation dose on a mcg/m<sup>2</sup> basis).

In the rabbit, fetal weight reduction and cleft palate were observed at a subcutaneous dose of 4 mcg/kg (less than the maximum recommended human daily inhalation dose on a mcg/m<sup>2</sup> basis). However, no teratogenic effects were reported at oral doses up to 300 mcg/kg (approximately 5 times the maximum recommended human daily inhalation dose on a mcg/m<sup>2</sup> basis) of fluticasone propionate. No fluticasone propionate was detected in the plasma in this study, consistent with the established low bioavailability following oral administration (see CLINICAL PHARMACOLOGY: Pharmacokinetics: *Fluticasone Propionate: Absorption*).

Fluticasone propionate crossed the placenta following administration of a subcutaneous dose of 100 mcg/kg to mice (less than the maximum recommended human daily inhalation dose on a mcg/m<sup>2</sup> basis), a subcutaneous or an oral dose of 100 mcg/kg to rats (equivalent to the maximum recommended human daily inhalation dose on a mcg/m<sup>2</sup> basis), and an oral dose of 300 mcg/kg to rabbits (approximately 5 times the maximum recommended human daily inhalation dose on a mcg/m<sup>2</sup> basis).

There are no adequate and well-controlled studies in pregnant women. ADVAIR HFA should be used during pregnancy only if the potential benefit justifies the potential risk to the fetus.

Experience with oral corticosteroids since their introduction in pharmacologic, as opposed to physiologic, doses suggests that rodents are more prone to teratogenic effects from corticosteroids than humans. In addition, because there is a natural increase in corticosteroid production during pregnancy, most women will require a lower exogenous corticosteroid dose and many will not need corticosteroid treatment during pregnancy.

**Salmeterol:** Pregnancy Category C. No teratogenic effects occurred in the rat at oral doses up to 2 mg/kg (approximately 190 times the maximum recommended human daily inhalation dose on a mg/m<sup>2</sup> basis). In pregnant Dutch rabbits administered oral doses of 1 mg/kg and above (approximately 25 times the maximum recommended human daily inhalation dose based on the comparison of the AUCs), salmeterol exhibited fetal toxic effects characteristically resulting from beta-adrenoceptor stimulation. These included precocious eyelid openings, cleft palate, sternebral fusion, limb and paw flexures, and delayed ossification of the frontal cranial bones. No significant effects occurred at an oral dose of 0.6 mg/kg (approximately 10 times the maximum recommended human daily inhalation dose based on comparison of the AUCs).

New Zealand White rabbits were less sensitive since only delayed ossification of the frontal cranial bones was seen at an oral dose of 10 mg/kg (approximately 1,900 times the maximum recommended human daily inhalation dose on a mg/m<sup>2</sup> basis). Extensive use of other beta-agonists has provided no evidence that these class effects in animals are relevant to their use in humans.

Salmeterol xinafoate crossed the placenta following oral administration of 10 mg/kg to mice and rats (approximately 480 and 970 times, respectively, the maximum recommended human daily inhalation dose on a mg/m<sup>2</sup> basis).

There are no adequate and well-controlled studies with salmeterol in pregnant women. Salmeterol should be used during pregnancy only if the potential benefit justifies the potential risk to the fetus.

**Use in Labor and Delivery:** There are no well-controlled human studies that have investigated effects of ADVAIR HFA on preterm labor or labor at term. Because of the potential for beta-agonist interference with uterine contractility, use of ADVAIR HFA for management of asthma during labor should be restricted to those patients in whom the benefits clearly outweigh the risks.

**Nursing Mothers:** Plasma levels of salmeterol, a component of ADVAIR HFA, after inhaled therapeutic doses are very low. In rats, salmeterol xinafoate is excreted in the milk. There are no data from controlled trials on the use of salmeterol by nursing mothers. It is not known whether fluticasone propionate, a component of ADVAIR HFA, is excreted in human breast milk. However, other corticosteroids have been detected in human milk. Subcutaneous administration to lactating rats of 10 mcg/kg tritiated fluticasone propionate (less than the maximum recommended human daily inhalation dose on a mcg/m<sup>2</sup> basis) resulted in measurable radioactivity in milk.

Since there are no data from controlled trials on the use of ADVAIR HFA by nursing mothers, a decision should be made whether to discontinue nursing or to discontinue ADVAIR HFA, taking into account the importance of ADVAIR HFA to the mother.

Caution should be exercised when ADVAIR HFA is administered to a nursing woman.

**Pediatric Use:** Thirty-eight (38) patients 12 to 17 years of age were treated with ADVAIR HFA in US pivotal clinical trials. Patients in this age-group demonstrated efficacy results similar to those observed in patients 18 years of age and older. There were no obvious differences in the type or frequency of adverse events reported in this age-group compared with patients 18 years of age and older.

The safety and effectiveness of ADVAIR HFA in children under 12 years have not been established.

Controlled clinical studies have shown that inhaled corticosteroids may cause a reduction in growth in pediatric patients. In these studies, the mean reduction in growth velocity was approximately 1 cm/year (range, 0.3 to 1.8 cm/year) and appears to depend upon dose and duration of exposure. This effect was observed in the absence of laboratory evidence of HPA axis suppression, suggesting that growth velocity is a more sensitive indicator of systemic

corticosteroid exposure in pediatric patients than some commonly used tests of HPA axis function. The long-term effects of this reduction in growth velocity associated with orally inhaled corticosteroids, including the impact on final adult height, are unknown. The potential for “catch-up” growth following discontinuation of treatment with orally inhaled corticosteroids has not been adequately studied. The effects on growth velocity of treatment with orally inhaled corticosteroids for over 1 year, including the impact on final adult height, are unknown. The growth of children and adolescents receiving orally inhaled corticosteroids, including ADVAIR HFA, should be monitored. If a child or adolescent on any corticosteroid appears to have growth suppression, the possibility that he/she is particularly sensitive to this effect of corticosteroids should be considered. The potential growth effects of prolonged treatment should be weighed against the clinical benefits obtained and the risks associated with alternative therapies. To minimize the systemic effects of orally inhaled corticosteroids, including ADVAIR HFA, each patient should be titrated to the lowest strength that effectively controls his/her asthma (see DOSAGE AND ADMINISTRATION).

**Geriatric Use:** Of the total number of patients in clinical studies treated with ADVAIR HFA, 41 were 65 years of age or older and 21 were 75 years of age or older. No overall differences in safety were observed between these patients and younger patients, and other reported clinical experience, including studies of the individual components, has not identified differences in responses between the elderly and younger patients, but greater sensitivity of some older individuals cannot be ruled out. As with other products containing beta<sub>2</sub>-agonists, special caution should be observed when using ADVAIR HFA in geriatric patients who have concomitant cardiovascular disease that could be adversely affected by beta<sub>2</sub>-agonists. Based on available data for ADVAIR HFA or its active components, no adjustment of dosage of ADVAIR HFA in geriatric patients is warranted.

## **ADVERSE REACTIONS**

**Long-acting beta<sub>2</sub>-adrenergic agonists, such as salmeterol, may increase the risk of asthma-related death. Data from a large, placebo-controlled US study that compared the safety of salmeterol (SEREVENT Inhalation Aerosol) or placebo added to usual asthma therapy showed an increase in asthma-related deaths in patients receiving salmeterol (see WARNINGS). Salmeterol is a component of ADVAIR HFA. However, the data from this study are not adequate to determine whether concurrent use of inhaled corticosteroids, such as fluticasone propionate, the other component of ADVAIR HFA, or other asthma controller therapy modifies the risk of asthma-related death.**

The incidence of common adverse events in Table 4 is based upon 2 placebo-controlled, 12-week, US clinical studies (Studies 1 and 3) and 1 active-controlled, 12-week, US clinical study (Study 2). A total of 1,008 adolescent and adult patients with asthma (556 females and 452 males) previously treated with albuterol alone, salmeterol, or inhaled corticosteroids were treated twice daily with 2 inhalations of ADVAIR HFA 45/21 or ADVAIR HFA 115/21, fluticasone

propionate CFC inhalation aerosol (44- or 110-mcg doses), salmeterol CFC inhalation aerosol 21 mcg, or placebo HFA inhalation aerosol.

**Table 4. Overall Adverse Events With  $\geq 3\%$  Incidence in US Controlled Clinical Trials With ADVAIR HFA Inhalation Aerosol in Patients With Asthma**

Adverse Events	ADVAIR HFA		Fluticasone Propionate CFC Inhalation Aerosol		Salmeterol CFC Inhalation Aerosol	Placebo HFA Inhalation Aerosol
	45/21 (n = 187) %	115/21 (n = 94) %	44 mcg (n = 186) %	110 mcg (n = 91) %	21 mcg (n = 274) %	(n = 176) %
Ear, nose, & throat						
Upper respiratory tract infection	16	24	13	15	17	13
Throat irritation	9	7	12	13	9	7
Upper respiratory inflammation	4	4	3	7	5	3
Hoarseness/dysphonia	3	1	2	0	1	0
Lower respiratory						
Viral respiratory infections	3	5	4	5	3	4
Neurology						
Headaches	21	15	24	16	20	11
Dizziness	4	1	1	0	<1	0
Gastrointestinal						
Nausea & vomiting	5	3	4	2	2	3
Viral gastrointestinal infections	4	2	2	0	1	2
Gastrointestinal signs & symptoms	3	2	2	1	1	1
Non-site specific						
Pain	3	1	2	1	2	2
Musculoskeletal						
Musculoskeletal pain	5	7	8	2	4	4
Muscle pain	4	1	1	1	3	<1
Drug interaction, overdose, & trauma						
Muscle injuries	3	0	2	1	3	2

Reproduction Menstruation symptoms	5	3	1	0	<1	<1
Psychiatry Intoxication & hangover	3	0	0	0	0	0
Average duration of exposure (days)	81.3	78.6	79.9	74.6	71.4	56.3

Table 4 includes all events (whether considered drug-related or nondrug-related by the investigator) that occurred at a rate of 3% or greater in any of the groups receiving ADVAIR HFA and were more common than in the placebo group. In considering these data, differences in average duration of exposure should be taken into account. These adverse reactions were mostly mild to moderate in severity.

Other adverse events that occurred in the groups receiving ADVAIR HFA in these studies with an incidence of 1% to 3% and that occurred at a greater incidence than with placebo were:

**Cardiovascular:** Tachycardia, arrhythmias, myocardial infarction.

**Drug Interaction, Overdose, and Trauma:** Postoperative complications, wounds and lacerations, soft tissue injuries, poisoning and toxicity, pressure-induced disorder.

**Ear, Nose, and Throat:** Ear, nose, and throat infection; ear signs and symptoms; rhinorrhea/postnasal drip; epistaxis; nasal congestion/blockage; laryngitis; unspecified oropharyngeal plaques; dryness of nose.

**Endocrine and Metabolic:** Weight gain.

**Eye:** Allergic eye disorders, eye edema and swelling.

**Gastrointestinal:** Gastrointestinal discomfort and pain, dental discomfort and pain, candidiasis mouth/throat, hyposalivation, gastrointestinal infections, disorders of hard tissue of teeth, hemorrhoids, gastrointestinal gaseous symptoms, abdominal discomfort and pain, constipation, oral abnormalities.

**Musculoskeletal:** Arthralgia and articular rheumatism, muscle cramps and spasms, musculoskeletal inflammation, bone and skeletal pain.

**Neurology:** Sleep disorders, migraines.

**Non-Site Specific:** Allergies and allergic reactions, viral infections, bacterial infections, candidiasis unspecified site, congestion, inflammation.

**Reproduction:** Bacterial reproductive infections.

**Respiratory:** Lower respiratory signs and symptoms, lower respiratory infections, lower respiratory hemorrhage.

**Skin:** Eczema, dermatitis and dermatosis.

**Urology:** Urinary infections.

Rare cases of immediate and delayed hypersensitivity reactions, including rash and other rare events of angioedema and bronchospasm, have been reported.

The incidence of common adverse events reported in Study 4, a 12-week, non-US clinical study of 509 patients previously treated with inhaled corticosteroids who were treated twice daily with 2 inhalations of ADVAIR HFA 230/21, fluticasone propionate CFC inhalation aerosol 220 mcg, or 1 inhalation of ADVAIR DISKUS 500/50 was similar to the incidences reported in Table 4.

**Observed During Clinical Practice:** In addition to adverse events reported from clinical trials, the following events have been identified during worldwide use of any formulation of ADVAIR, fluticasone propionate, and/or salmeterol regardless of indication. Because they are reported voluntarily from a population of unknown size, estimates of frequency cannot be made. These events have been chosen for inclusion due to either their seriousness, frequency of reporting, or causal connection to ADVAIR, fluticasone propionate, and/or salmeterol or a combination of these factors.

In extensive US and worldwide postmarketing experience with salmeterol, a component of ADVAIR HFA, serious exacerbations of asthma, including some that have been fatal, have been reported. In most cases, these have occurred in patients with severe asthma and/or in some patients in whom asthma has been acutely deteriorating (see WARNINGS), but they have also occurred in a few patients with less severe asthma. It was not possible from these reports to determine whether salmeterol contributed to these events.

**Cardiovascular:** Arrhythmias (including atrial fibrillation, extrasystoles, supraventricular tachycardia), hypertension, ventricular tachycardia.

**Ear, Nose, and Throat:** Aphonia, earache, facial and oropharyngeal edema, paranasal sinus pain, rhinitis, throat soreness and irritation, tonsillitis.

**Endocrine and Metabolic:** Cushing syndrome, Cushingoid features, growth velocity reduction in children/adolescents, hypercorticism, hyperglycemia, osteoporosis.

**Eye:** Cataracts, glaucoma.

**Gastrointestinal:** Dyspepsia, xerostomia.

**Hepatobiliary Tract and Pancreas:** Abnormal liver function tests.

**Musculoskeletal:** Back pain, myositis.

**Neurology:** Paresthesia, restlessness.

**Non-Site Specific:** Fever, immediate and delayed hypersensitivity reaction, pallor.

**Psychiatry:** Agitation, aggression, anxiety, depression. Behavioral changes, including hyperactivity and irritability, have been reported very rarely and primarily in children.

**Respiratory:** Asthma; asthma exacerbation; chest congestion; chest tightness; cough; dyspnea; immediate bronchospasm; influenza; paradoxical bronchospasm; tracheitis; wheezing; pneumonia; reports of upper respiratory symptoms of laryngeal spasm, irritation, or swelling; stridor; choking.

**Skin:** Contact dermatitis, contusions, ecchymoses, photodermatitis, pruritus.

**Urogenital:** Dysmenorrhea, irregular menstrual cycle, pelvic inflammatory disease, vaginal candidiasis, vaginitis, vulvovaginitis.

**Eosinophilic Conditions:** In rare cases, patients on inhaled fluticasone propionate, a component of ADVAIR HFA, may present with systemic eosinophilic conditions, with some patients presenting with clinical features of vasculitis consistent with Churg-Strauss syndrome, a condition that is often treated with systemic corticosteroid therapy. These events usually, but not always, have been associated with the reduction and/or withdrawal of oral corticosteroid therapy following the introduction of fluticasone propionate. Cases of serious eosinophilic conditions have also been reported with other inhaled corticosteroids in this clinical setting. While ADVAIR HFA should not be used for transferring patients from systemic corticosteroid therapy, physicians should be alert to eosinophilia, vasculitic rash, worsening pulmonary symptoms, cardiac complications, and/or neuropathy presenting in their patients. A causal relationship between fluticasone propionate and these underlying conditions has not been established (see PRECAUTIONS: General: *Eosinophilic Conditions*).

## OVERDOSAGE

**ADVAIR HFA Inhalation Aerosol:** No deaths occurred in rats given a single-dose combination of salmeterol 3.6 mg/kg and fluticasone propionate 1.9 mg/kg given as the inhalation powder (approximately 290 and 15 times, respectively, the maximum recommended human daily inhalation dose on a mg/m<sup>2</sup> basis).

**Fluticasone Propionate:** Chronic overdosage with fluticasone propionate may result in signs/symptoms of hypercorticism (see PRECAUTIONS: General: *Metabolic and Other Effects*). Inhalation by healthy volunteers of a single dose of 4,000 mcg of fluticasone propionate inhalation powder or single doses of 1,760 or 3,520 mcg of fluticasone propionate CFC inhalation aerosol were well tolerated. Fluticasone propionate given by inhalation aerosol at dosages of 1,320 mcg twice daily for 7 to 15 days to healthy human volunteers was also well tolerated. Repeat oral doses up to 80 mg daily for 10 days in healthy volunteers and repeat oral doses up to 20 mg daily for 42 days in patients were well tolerated. Adverse reactions were of mild or moderate severity, and incidences were similar in active and placebo treatment groups. In mice the oral median lethal dose was >1,000 mg/kg (>4,400 times the maximum recommended human daily inhalation dose on a mg/m<sup>2</sup> basis). In rats the subcutaneous median lethal dose was >1,000 mg/kg (>8,800 times the maximum recommended human daily inhalation dose on a mg/m<sup>2</sup> basis).

**Salmeterol:** The expected signs and symptoms with overdosage of salmeterol are those of excessive beta-adrenergic stimulation and/or occurrence or exaggeration of any of the signs and symptoms listed under ADVERSE REACTIONS, e.g., seizures, angina, hypertension or hypotension, tachycardia with rates up to 200 beats/min, arrhythmias, nervousness, headache, tremor, muscle cramps, dry mouth, palpitation, nausea, dizziness, fatigue, malaise, and insomnia. Overdosage with salmeterol may be expected to result in exaggeration of the pharmacologic adverse effects associated with beta-adrenoceptor agonists, including tachycardia and/or arrhythmia, tremor, headache, and muscle cramps. Overdosage with salmeterol can lead to

clinically significant prolongation of the QTc interval, which can produce ventricular arrhythmias. Other signs of overdosage may include hypokalemia and hyperglycemia.

As with all sympathomimetic medications, cardiac arrest and even death may be associated with abuse of salmeterol.

Treatment consists of discontinuation of salmeterol together with appropriate symptomatic therapy. The judicious use of a cardioselective beta-receptor blocker may be considered, bearing in mind that such medication can produce bronchospasm. There is insufficient evidence to determine if dialysis is beneficial for overdosage of salmeterol. Cardiac monitoring is recommended in cases of overdosage.

No deaths were seen in rats given salmeterol at an inhalation dose of 2.9 mg/kg (approximately 280 times the maximum recommended human daily inhalation dose on a mg/m<sup>2</sup> basis) and in dogs at an inhalation dose of 0.7 mg/kg (approximately 230 times the maximum recommended human daily inhalation dose on a mg/m<sup>2</sup> basis). By the oral route, no deaths occurred in mice at 150 mg/kg (approximately 7,200 times the maximum recommended human daily inhalation dose on a mg/m<sup>2</sup> basis) and in rats at 1,000 mg/kg (approximately 97,000 times the maximum recommended human daily inhalation dose on a mg/m<sup>2</sup> basis).

## **DOSAGE AND ADMINISTRATION**

ADVAIR HFA should be administered by the orally inhaled route only in patients 12 years of age and older. ADVAIR HFA should not be used for transferring patients from systemic corticosteroid therapy. ADVAIR HFA has not been studied in patients under 12 years of age or in patients with COPD.

Long-acting beta<sub>2</sub>-adrenergic agonists, such as salmeterol, one of the active ingredients in ADVAIR HFA, may increase the risk of asthma-related death (see WARNINGS). Therefore, when treating patients with asthma, physicians should only prescribe ADVAIR HFA for patients not adequately controlled on other asthma-controller medications (e.g., low- to medium-dose inhaled corticosteroids) or whose disease severity clearly warrants initiation of treatment with 2 maintenance therapies. ADVAIR HFA is not indicated in patients whose asthma can be successfully managed by inhaled corticosteroids along with occasional use of inhaled, short-acting beta<sub>2</sub>-agonists.

ADVAIR HFA is available in 3 strengths, ADVAIR HFA 45/21 Inhalation Aerosol, ADVAIR HFA 115/21 Inhalation Aerosol, and ADVAIR HFA 230/21 Inhalation Aerosol, containing 45, 115, and 230 mcg of fluticasone propionate, respectively, and 21 mcg of salmeterol per inhalation.

ADVAIR HFA should be administered as 2 inhalations twice daily every day. More frequent administration (more than twice daily) or a higher number of inhalations (more than 2 inhalations twice daily) of the prescribed strength of ADVAIR HFA is not recommended as some patients are more likely to experience adverse effects with higher doses of salmeterol. The safety and efficacy of ADVAIR HFA when administered in excess of recommended doses have not been established.

If symptoms arise in the period between doses, an inhaled, short-acting beta<sub>2</sub>-agonist should be taken for immediate relief.

Patients who are receiving ADVAIR HFA twice daily should not use additional salmeterol or other inhaled, long-acting beta<sub>2</sub>-agonists (e.g., formoterol) for prevention of EIB or for any other reason.

For patients 12 years of age and older, the dosage is 2 inhalations twice daily (morning and evening, approximately 12 hours apart).

The recommended starting dosages for ADVAIR HFA are based upon patients' current asthma therapy.

- For patients not adequately controlled on an inhaled corticosteroid, Table 5 provides the recommended starting dosage.
- For patients not currently on inhaled corticosteroids, whose disease severity clearly warrants initiation of treatment with 2 maintenance therapies, the recommended starting dosage is 2 inhalations of ADVAIR HFA 45/21 or ADVAIR HFA 115/21 twice daily (see INDICATIONS AND USAGE).

The maximum recommended dosage is 2 inhalations of ADVAIR HFA 230/21 twice daily.

**For all patients it is desirable to titrate to the lowest effective strength after adequate asthma stability is achieved.**

**Table 5. Recommended Dosages of ADVAIR HFA Inhalation Aerosol for Patients Not Adequately Controlled on Inhaled Corticosteroids**

Current <b>Daily Dose</b> of Inhaled Corticosteroid		Recommended Strength of ADVAIR HFA (2 inhalations twice daily)
Beclomethasone dipropionate HFA inhalation aerosol	≤160 mcg	45/21
	320 mcg	115/21
	640 mcg	230/21
Budesonide inhalation powder	≤400 mcg	45/21
	800-1,200 mcg	115/21
	1,600 mcg*	230/21
Flunisolide CFC inhalation aerosol	≤1,000 mcg	45/21
	1,250-2,000 mcg	115/21
Flunisolide HFA inhalation aerosol	≤320 mcg	45/21
	640 mcg	115/21
Fluticasone propionate HFA inhalation aerosol	≤176 mcg	45/21
	440 mcg	115/21
	660-880 mcg*	230/21
Fluticasone propionate inhalation powder	≤200 mcg	45/21
	500 mcg	115/21
	1,000 mcg*	230/21
Mometasone furoate inhalation powder	220 mcg	45/21
	440 mcg	115/21
	880 mcg	230/21
Triamcinolone acetonide inhalation aerosol	≤1,000 mcg	45/21
	1,100-1,600 mcg	115/21

\* ADVAIR HFA should not be used for transferring patients from systemic corticosteroid therapy.

Improvement in asthma control following inhaled administration of ADVAIR HFA can occur within 30 minutes of beginning treatment, although maximum benefit may not be achieved for 1 week or longer after starting treatment. Individual patients will experience a variable time to onset and degree of symptom relief.

For patients who do not respond adequately to the starting dosage after 2 weeks of therapy, replacing the current strength of ADVAIR HFA with a higher strength may provide additional improvement in asthma control.

If a previously effective dosage regimen of ADVAIR HFA fails to provide adequate improvement in asthma control, the therapeutic regimen should be reevaluated and additional therapeutic options, e.g., replacing the current strength of ADVAIR HFA with a higher strength, adding additional inhaled corticosteroid, or initiating oral corticosteroids, should be considered.

ADVAIR HFA should be primed before using for the first time by releasing 4 test sprays into the air away from the face, shaking well for 5 seconds before each spray. In cases where the inhaler has not been used for more than 4 weeks or when it has been dropped, prime the inhaler again by releasing 2 test sprays into the air away from the face, shaking well for 5 seconds before each spray.

**Geriatric Use:** In studies where geriatric patients (65 years of age or older, see PRECAUTIONS: Geriatric Use) have been treated with ADVAIR HFA, efficacy and safety did not differ from that in younger patients. Based on available data for ADVAIR HFA and its active components, no dosage adjustment is recommended.

## HOW SUPPLIED

Each strength of ADVAIR HFA Inhalation Aerosol is supplied in a 12-g pressurized aluminum canister containing 120 metered actuations in a box of 1. \* Each canister is fitted with a counter, supplied with a purple actuator with a light purple strapcap, and sealed in a plastic-coated, moisture-protective foil pouch with a desiccant that should be discarded when the pouch is opened. Each canister is packaged with a Medication Guide leaflet.

\*NDC 0173-0715-20 ADVAIR HFA 45/21 Inhalation Aerosol

\*NDC 0173-0716-20 ADVAIR HFA 115/21 Inhalation Aerosol

\*NDC 0173-0717-20 ADVAIR HFA 230/21 Inhalation Aerosol

**The purple actuator supplied with ADVAIR HFA Inhalation Aerosol should not be used with any other product canisters, and actuators from other products should not be used with an ADVAIR HFA Inhalation Aerosol canister.**

**The correct amount of medication in each actuation cannot be assured after the counter reads 000, even though the canister is not completely empty and will continue to operate. The inhaler should be discarded when the counter reads 000.**

**Keep out of reach of children. Avoid spraying in eyes.**

**Contents Under Pressure: Do not puncture. Do not use or store near heat or open flame. Exposure to temperatures above 120°F may cause bursting. Never throw container into fire or incinerator.**

**Store at 25°C (77°F); excursions permitted to 15°-30°C (59°-86°F). Store the inhaler with the mouthpiece down. For best results, the inhaler should be at room temperature before use. SHAKE WELL FOR 5 SECONDS BEFORE USING.**

ADVAIR HFA Inhalation Aerosol does not contain chlorofluorocarbons (CFCs) as the propellant.

## PATIENT INFORMATION

### MEDICATION GUIDE

**ADVAIR<sup>®</sup> HFA [*ad' vair*] 45/21 Inhalation Aerosol  
(fluticasone propionate 45 mcg and salmeterol 21 mcg)**

**ADVAIR<sup>®</sup> HFA 115/21 Inhalation Aerosol**  
**(fluticasone propionate 115 mcg and salmeterol 21 mcg)**

**ADVAIR<sup>®</sup> HFA 230/21 Inhalation Aerosol**  
**(fluticasone propionate 230 mcg and salmeterol 21 mcg)**

Read this Medication Guide carefully before you start to use ADVAIR HFA Inhalation Aerosol.

Keep this Medication Guide because it has important summary information about ADVAIR HFA. This Medication Guide does not contain all the information about your medicine. If you have any questions or are not sure about something, you should ask your doctor or pharmacist.

Read the new Medication Guide that comes with each refill of your prescription because there may be new information.

**What is the most important information I should know about ADVAIR HFA?**

- **ADVAIR HFA contains 2 medicines:**
  - **fluticasone propionate (the same medicine found in FLOVENT<sup>®</sup>)**, an inhaled corticosteroid medicine. Inhaled corticosteroids help to decrease inflammation in the lungs. Inflammation in the lungs can lead to asthma symptoms.
  - **salmeterol (the same medicine found in SEREVENT<sup>®</sup>)**, a long-acting beta<sub>2</sub>-agonist (LABA) medicine. LABA medicines are used in patients with asthma. LABA medicines help the muscles around the airways in your lungs stay relaxed to prevent symptoms, such as wheezing and shortness of breath. These symptoms can happen when the muscles around the airways tighten. This makes it hard to breathe. In severe cases, wheezing can stop your breathing and cause death if not treated right away.
- **In patients with asthma, LABA medicines, such as salmeterol (one of the medicines in ADVAIR HFA), may increase the chance of death from asthma problems.** In a large asthma study, more patients who used salmeterol died from asthma problems compared with patients who did not use salmeterol. It is not known whether fluticasone propionate, the other medicine in ADVAIR HFA, changes your chance of death from asthma problems seen with salmeterol. Talk with your healthcare provider about this risk and the benefits of treating your asthma with ADVAIR HFA.
- **ADVAIR HFA does not relieve sudden symptoms. Always have a short-acting beta<sub>2</sub>-agonist medicine with you to treat sudden symptoms. If you do not have an inhaled, short-acting bronchodilator, contact your healthcare provider to have one prescribed for you.**
- **Do not stop using ADVAIR HFA unless told to do so by your healthcare provider because your symptoms might get worse.**

- **ADVAIR HFA should be used only if your healthcare provider decides that another asthma-controller medicine alone does not control your asthma or that you need 2 asthma-controller medicines.**
- **Call your healthcare provider if breathing problems worsen over time while using ADVAIR HFA. You may need different treatment.**
- **Get emergency medical care if:**
  - **breathing problems worsen quickly, and**
  - **you use your short-acting beta<sub>2</sub>-agonist medicine, but it does not relieve your breathing problems.**

### **What is ADVAIR HFA?**

ADVAIR HFA combines an inhaled corticosteroid medicine, fluticasone propionate (the same medicine found in FLOVENT) and a LABA medicine, salmeterol (the same medicine found in SEREVENT).

ADVAIR HFA is used long term, twice a day to control symptoms of asthma, and prevent symptoms such as wheezing in adults and adolescents 12 years of age and older.

**ADVAIR HFA contains salmeterol (the same medicine found in SEREVENT). Because LABA medicines, such as salmeterol, may increase the chance of death from asthma problems, ADVAIR HFA is not for adults and children with asthma who:**

- are well controlled with another asthma-controller medicine, such as a low to medium dose of an inhaled corticosteroid medicine
- only need short-acting beta<sub>2</sub>-agonist medicines once in awhile

### **Who should not use ADVAIR HFA?**

Do not use ADVAIR HFA:

- to treat sudden severe symptoms of asthma
- if you are allergic to any of the ingredients in ADVAIR HFA. See the end of this Medication Guide for a list of ingredients in ADVAIR HFA.

### **What should I tell my healthcare provider before using ADVAIR HFA?**

**Tell your healthcare provider about all of your health conditions, including if you:**

- **have heart problems**
- **have high blood pressure**
- **have seizures**
- **have thyroid problems**
- **have diabetes**
- **have liver problems**
- **have osteoporosis**
- **have an immune system problem**

- **are pregnant or planning to become pregnant.** It is not known if ADVAIR HFA may harm your unborn baby.
- **are breastfeeding.** It is not known if ADVAIR HFA passes into your milk and if it can harm your baby.
- **are allergic to ADVAIR HFA or any other medicines**
- **are exposed to chickenpox or measles**

Tell your healthcare provider about all the medicines you take including prescription and non-prescription medicines, vitamins, and herbal supplements. ADVAIR HFA and certain other medicines may interact with each other. This may cause serious side effects. Especially, tell your healthcare provider if you take ritonavir. The anti-HIV medicines NORVIR<sup>®</sup> (ritonavir capsules) Soft Gelatin, NORVIR (ritonavir oral solution), and KALETRA<sup>®</sup> (lopinavir/ritonavir) Tablets contain ritonavir.

Know the medicines you take. Keep a list and show it to your healthcare provider and pharmacist each time you get a new medicine.

### How do I use ADVAIR HFA?

**See the step-by-step instructions for using ADVAIR HFA at the end of this Medication Guide.** Do not use ADVAIR HFA unless your healthcare provider has taught you and you understand everything. Ask your healthcare provider or pharmacist if you have any questions.

- Use ADVAIR HFA exactly as prescribed. **Do not use ADVAIR HFA more often than prescribed.** ADVAIR HFA comes in 3 strengths. Your healthcare provider has prescribed the one that is best for your condition.
- The usual dose of ADVAIR HFA is 2 inhalations twice a day (morning and evening). The 2 doses should be about 12 hours apart. Rinse your mouth with water after using ADVAIR HFA.
- If you miss a dose of ADVAIR HFA, just skip that dose. Take your next dose at your usual time. Do not take 2 doses at one time.
- **While you are using ADVAIR HFA twice a day, do not use other medicines that contain a LABA for any reason. Other LABA-containing medicines include ADVAIR DISKUS<sup>®</sup> (fluticasone propionate and salmeterol inhalation powder), SEREVENT<sup>®</sup> DISKUS<sup>®</sup> (salmeterol xinafoate inhalation powder), FORADIL<sup>®</sup> AEROLIZER<sup>®</sup> (formoterol fumarate inhalation powder), SYMBICORT<sup>®</sup> (budesonide and formoterol fumarate dihydrate) Inhalation Aerosol, PERFOROMIST<sup>™</sup> (formoterol fumarate) Inhalation Solution, and BROVANA<sup>™</sup> (arformoterol tartrate) Inhalation Solution.**
- Do not change or stop any of your medicines used to control or treat your breathing problems. Your healthcare provider will adjust your medicines as needed.

- Make sure you always have a short-acting beta<sub>2</sub>-agonist medicine with you. Use your short-acting beta<sub>2</sub>-agonist medicine if you have breathing problems between doses of ADVAIR HFA.
- **Call your healthcare provider or get medical care right away if:**
  - your breathing problems worsen with ADVAIR HFA
  - you need to use your short-acting beta<sub>2</sub>-agonist medicine more often than usual
  - your short-acting beta<sub>2</sub>-agonist medicine does not work as well for you at relieving symptoms
  - you need to use 4 or more inhalations of your short-acting beta<sub>2</sub>-agonist medicine for 2 or more days in a row
  - you use 1 whole canister of your short-acting beta<sub>2</sub>-agonist medicine in 8 weeks' time
  - your peak flow meter results decrease. Your healthcare provider will tell you the numbers that are right for you.
  - you have asthma and your symptoms do not improve after using ADVAIR HFA regularly for 1 week

#### **What are the possible side effects with ADVAIR HFA?**

**ADVAIR HFA contains salmeterol (the same medicine found in SEREVENT). In patients with asthma, LABA medicines, such as salmeterol, may increase the chance of death from asthma problems.** See “What is the most important information I should know about ADVAIR HFA?”

**Other possible side effects with ADVAIR HFA include:**

- **serious allergic reactions including rash; hives; swelling of the face, mouth, and tongue; and breathing problems.** Call your healthcare provider or get emergency medical care if you get any symptoms of a serious allergic reaction.
- **increased blood pressure**
- **a fast and irregular heartbeat**
- **chest pain**
- **headache**
- **tremor**
- **nervousness**
- **immune system effects and a higher chance for infections**
- **lower bone mineral density.** This may be a problem for people who already have a higher chance for low bone density (osteoporosis).
- **eye problems including glaucoma and cataracts.** You should have regular eye exams while using ADVAIR HFA.
- **slowed growth in children.** A child's growth should be checked often.
- **throat irritation**
- **pneumonia.** ADVAIR HFA contains the same medicine found in ADVAIR DISKUS. ADVAIR DISKUS is used to treat people with asthma and people with chronic obstructive

pulmonary disease (COPD). People with COPD have a higher chance of getting pneumonia. ADVAIR DISKUS may increase the chance of getting pneumonia. ADVAIR HFA has not been studied in people with COPD.

Common side effects of ADVAIR HFA include upper respiratory tract infection and headache.

Tell your healthcare provider about any side effect that bothers you or that does not go away.

These are not all the side effects with ADVAIR HFA. Ask your healthcare provider or pharmacist for more information.

Call your doctor for medical advice about side effects. You may report side effects to FDA at 1-800-FDA-1088.

### **How should I store ADVAIR HFA?**

Store at room temperature with the mouthpiece down.

**Contents Under Pressure:** Do not puncture. Do not use or store near heat or open flame. Exposure to temperatures above 120°F may cause bursting.

Do not throw into fire or an incinerator.

**Keep ADVAIR HFA and all medicines out of the reach of children.**

### **General information about ADVAIR HFA**

Medicines are sometimes prescribed for purposes other than those listed in a Medication Guide. Do not use ADVAIR HFA for a condition for which it was not prescribed. Do not give your ADVAIR HFA to other people, even if they have the same condition that you have. It may harm them.

This Medication Guide summarizes the most important information about ADVAIR HFA. If you would like more information, talk with your healthcare provider or pharmacist. You can ask your healthcare provider or pharmacist for information about ADVAIR HFA that was written for healthcare professionals. You can also contact the company that makes ADVAIR HFA (toll free) at 1-888-825-5249 or at [www.advair.com](http://www.advair.com).

### **What are the ingredients in ADVAIR HFA?**

Active ingredients: fluticasone propionate, salmeterol xinafoate

Inactive ingredient: propellant HFA-134a

### **How to use your ADVAIR HFA**

#### **The parts of your ADVAIR HFA:**

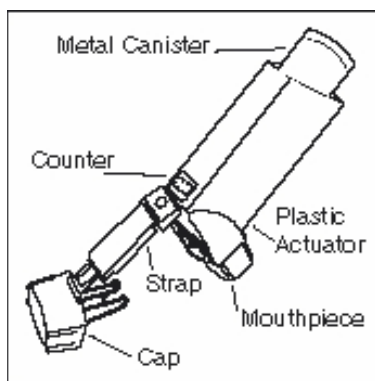

**Figure 1**

There are 2 main parts to your ADVAIR HFA inhaler—the metal canister that holds the medicine and the purple plastic actuator that sprays the medicine from the canister (see Figure 1).

The inhaler also has a cap that covers the mouthpiece of the actuator. The strap on the cap will stay attached to the actuator.

**Do not use the actuator with a canister of medicine from any other inhaler. Do not use an ADVAIR HFA canister with an actuator from any other inhaler.**

The canister has a counter to show how many sprays of medicine you have left. The number shows through a window in the back of the actuator.

The counter starts at 124. The number will count down by 1 each time you spray the inhaler. The counter will stop counting at 000.

**Never try to change the numbers or take the counter off the metal canister.** The counter cannot be reset, and it is permanently attached to the canister.

**Before using your ADVAIR HFA:**

Take the inhaler out of the foil pouch. Safely throw away the foil pouch and the drying packet that comes inside the pouch. The counter should read 124.

The inhaler should be at room temperature before you use it.

Check each time to make sure the canister fits firmly in the plastic actuator. Also look into the mouthpiece to make sure there are no foreign objects there, especially if the strap is no longer attached to the actuator or if the cap is not being used to cover the mouthpiece.

**Priming your ADVAIR HFA:**

Before you use ADVAIR HFA for the first time, you must prime the inhaler so that you will get the right amount of medicine when you use it. To prime the inhaler, take the cap off the mouthpiece and shake the inhaler well for 5 seconds. Then spray it 1 time into the air away from your face. Shake and spray the inhaler like this 3 more times to finish priming it. **Avoid spraying in eyes.** The counter should now read 120.

You must prime your inhaler again if you have not used it in more than 4 weeks or if you have dropped it. Take the cap off the mouthpiece, shake the inhaler well for 5 seconds, and spray it into the air away from your face. Shake and spray the inhaler like this 1 more time to finish priming it.

**Instructions for taking a dose from your ADVAIR HFA:**

Read through the 7 steps below before using ADVAIR HFA. If you have any questions, ask your doctor or pharmacist.

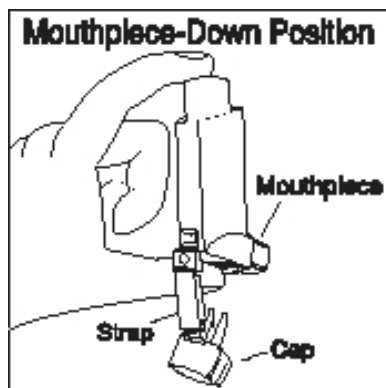

Figure 2

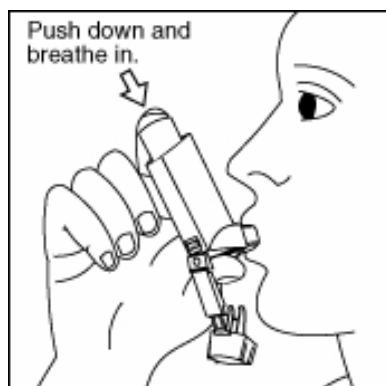

Figure 3

1. Take the cap off the mouthpiece of the actuator. **Shake the inhaler well** for 5 seconds before each spray.
2. Hold the inhaler with the mouthpiece down (see Figure 2). **Breathe out through your mouth** and push as much air from your lungs as you can. Put the mouthpiece in your mouth and close your lips around it.
3. **Push the top of the canister all the way down while you breathe in deeply and slowly through your mouth** (see Figure 3). Right after the spray comes out, take your finger off the canister. After you have breathed in all the way, take the inhaler out of your mouth and close your mouth.
4. **Hold your breath as long as you can**, up to 10 seconds, then breathe normally.
5. Wait about 30 seconds and **shake** the inhaler again for 5 seconds. Repeat steps 2 through 4.
6. After you finish taking this medicine, rinse your mouth with water. Spit out the water. Do not swallow it.
7. Put the cap back on the mouthpiece after every time you use the inhaler, and make sure it snaps firmly into place.

**When to replace your ADVAIR HFA:**

- **When the counter reads 020**, you should refill your prescription or ask your doctor if you need another prescription for ADVAIR HFA.
- **Throw the inhaler away** when the counter reads 000. You should not keep using the inhaler when the counter reads 000 because you will not receive the right amount of medicine.
- **Do not use the inhaler** after the expiration date, which is on the packaging it comes in.

**How to clean your ADVAIR HFA:**

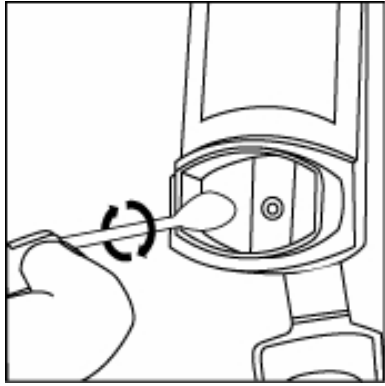

**Figure 4**

Clean the inhaler at least once a week after your evening dose. It is important to keep the canister and plastic actuator clean so the medicine will not build-up and block the spray.

1. Take the cap off the mouthpiece. The strap on the cap will stay attached to the actuator. Do not take the canister out of the plastic actuator.
2. Use a dry cotton swab to clean the small circular opening where the medicine sprays out of the canister. Carefully twist the swab in a circular motion to take off any medicine (see Figure 4).
3. Wipe the inside of the mouthpiece with a clean tissue dampened with water. Let the actuator air-dry overnight.
4. Put the cap back on the mouthpiece after the actuator has dried.

**This Medication Guide has been approved by the U.S. Food and Drug Administration.**

November 2008

ADH:3MG

ADVAIR, ADVAIR DISKUS, DISKUS, FLONASE, FLOVENT, SEREVENT, and VENTOLIN are registered trademarks of GlaxoSmithKline.

The other brands listed are trademarks of their respective owners and are not trademarks of GlaxoSmithKline. The makers of these brands are not affiliated with and do not endorse GlaxoSmithKline or its products.



GlaxoSmithKline

Research Triangle Park, NC 27709

©2008, GlaxoSmithKline. All rights reserved.

November 2008

ADH:3PI

---

**PHARMACIST—DETACH HERE AND GIVE MEDICATION GUIDE TO PATIENT**

---

## MEDICATION GUIDE

**ADVAIR<sup>®</sup> HFA [*ad' vair*] 45/21 Inhalation Aerosol  
(fluticasone propionate 45 mcg and salmeterol 21 mcg)**

**ADVAIR<sup>®</sup> HFA 115/21 Inhalation Aerosol  
(fluticasone propionate 115 mcg and salmeterol 21 mcg)**

**ADVAIR<sup>®</sup> HFA 230/21 Inhalation Aerosol  
(fluticasone propionate 230 mcg and salmeterol 21 mcg)**

Read this Medication Guide carefully before you start to use ADVAIR HFA Inhalation Aerosol.

Keep this Medication Guide because it has important summary information about ADVAIR HFA. This Medication Guide does not contain all the information about your medicine. If you have any questions or are not sure about something, you should ask your doctor or pharmacist.

Read the new Medication Guide that comes with each refill of your prescription because there may be new information.

### What is the most important information I should know about ADVAIR HFA?

- **ADVAIR HFA contains 2 medicines:**
  - **fluticasone propionate (the same medicine found in FLOVENT<sup>®</sup>)**, an inhaled corticosteroid medicine. Inhaled corticosteroids help to decrease inflammation in the lungs. Inflammation in the lungs can lead to asthma symptoms.
  - **salmeterol (the same medicine found in SEREVENT<sup>®</sup>)**, a long-acting beta<sub>2</sub>-agonist (LABA) medicine. LABA medicines are used in patients with asthma. LABA medicines help the muscles around the airways in your lungs stay relaxed to prevent symptoms, such as wheezing and shortness of breath. These symptoms can happen when the muscles around the airways tighten. This makes it hard to breathe. In severe cases, wheezing can stop your breathing and cause death if not treated right away.
- **In patients with asthma, LABA medicines, such as salmeterol (one of the medicines in ADVAIR HFA), may increase the chance of death from asthma problems.** In a large asthma study, more patients who used salmeterol died from asthma problems compared with patients who did not use salmeterol. It is not known whether fluticasone propionate, the other medicine in ADVAIR HFA, changes your chance of death from asthma problems seen with salmeterol. Talk with your healthcare provider about this risk and the benefits of treating your asthma with ADVAIR HFA.
- **ADVAIR HFA does not relieve sudden symptoms. Always have a short-acting beta<sub>2</sub>-agonist medicine with you to treat sudden symptoms. If you do not have an**

**inhaled, short-acting bronchodilator, contact your healthcare provider to have one prescribed for you.**

- **Do not stop using ADVAIR HFA unless told to do so by your healthcare provider because your symptoms might get worse.**
- **ADVAIR HFA should be used only if your healthcare provider decides that another asthma-controller medicine alone does not control your asthma or that you need 2 asthma-controller medicines.**
- **Call your healthcare provider if breathing problems worsen over time while using ADVAIR HFA. You may need different treatment.**
- **Get emergency medical care if:**
  - **breathing problems worsen quickly, and**
  - **you use your short-acting beta<sub>2</sub>-agonist medicine, but it does not relieve your breathing problems.**

#### **What is ADVAIR HFA?**

ADVAIR HFA combines an inhaled corticosteroid medicine, fluticasone propionate (the same medicine found in FLOVENT) and a LABA medicine, salmeterol (the same medicine found in SEREVENT).

ADVAIR HFA is used long term, twice a day to control symptoms of asthma, and prevent symptoms such as wheezing in adults and adolescents 12 years of age and older.

**ADVAIR HFA contains salmeterol (the same medicine found in SEREVENT). Because LABA medicines, such as salmeterol, may increase the chance of death from asthma problems, ADVAIR HFA is not for adults and children with asthma who:**

- are well controlled with another asthma-controller medicine, such as a low to medium dose of an inhaled corticosteroid medicine
- only need short-acting beta<sub>2</sub>-agonist medicines once in awhile

#### **Who should not use ADVAIR HFA?**

Do not use ADVAIR HFA:

- to treat sudden severe symptoms of asthma
- if you are allergic to any of the ingredients in ADVAIR HFA. See the end of this Medication Guide for a list of ingredients in ADVAIR HFA.

#### **What should I tell my healthcare provider before using ADVAIR HFA?**

**Tell your healthcare provider about all of your health conditions, including if you:**

- **have heart problems**
- **have high blood pressure**
- **have seizures**
- **have thyroid problems**

- **have diabetes**
- **have liver problems**
- **have osteoporosis**
- **have an immune system problem**
- **are pregnant or planning to become pregnant.** It is not known if ADVAIR HFA may harm your unborn baby.
- **are breastfeeding.** It is not known if ADVAIR HFA passes into your milk and if it can harm your baby.
- **are allergic to ADVAIR HFA or any other medicines**
- **are exposed to chickenpox or measles**

Tell your healthcare provider about all the medicines you take including prescription and non-prescription medicines, vitamins, and herbal supplements. ADVAIR HFA and certain other medicines may interact with each other. This may cause serious side effects. Especially, tell your healthcare provider if you take ritonavir. The anti-HIV medicines NORVIR<sup>®</sup> (ritonavir capsules) Soft Gelatin, NORVIR (ritonavir oral solution), and KALETRA<sup>®</sup> (lopinavir/ritonavir) Tablets contain ritonavir.

Know the medicines you take. Keep a list and show it to your healthcare provider and pharmacist each time you get a new medicine.

### How do I use ADVAIR HFA?

**See the step-by-step instructions for using ADVAIR HFA at the end of this Medication Guide.** Do not use ADVAIR HFA unless your healthcare provider has taught you and you understand everything. Ask your healthcare provider or pharmacist if you have any questions.

- Use ADVAIR HFA exactly as prescribed. **Do not use ADVAIR HFA more often than prescribed.** ADVAIR HFA comes in 3 strengths. Your healthcare provider has prescribed the one that is best for your condition.
- The usual dose of ADVAIR HFA is 2 inhalations twice a day (morning and evening). The 2 doses should be about 12 hours apart. Rinse your mouth with water after using ADVAIR HFA.
- If you miss a dose of ADVAIR HFA, just skip that dose. Take your next dose at your usual time. Do not take 2 doses at one time.
- **While you are using ADVAIR HFA twice a day, do not use other medicines that contain a LABA for any reason. Other LABA-containing medicines include ADVAIR DISKUS<sup>®</sup> (fluticasone propionate and salmeterol inhalation powder), SEREVENT<sup>®</sup> DISKUS<sup>®</sup> (salmeterol xinafoate inhalation powder), FORADIL<sup>®</sup> AEROLIZER<sup>®</sup> (formoterol fumarate inhalation powder), SYMBICORT<sup>®</sup> (budesonide and formoterol fumarate dihydrate) Inhalation Aerosol, PERFOROMIST<sup>™</sup> (formoterol fumarate) Inhalation Solution, and BROVANA<sup>™</sup> (arformoterol tartrate) Inhalation Solution.**

- Do not change or stop any of your medicines used to control or treat your breathing problems. Your healthcare provider will adjust your medicines as needed.
- Make sure you always have a short-acting beta<sub>2</sub>-agonist medicine with you. Use your short-acting beta<sub>2</sub>-agonist medicine if you have breathing problems between doses of ADVAIR HFA.
- **Call your healthcare provider or get medical care right away if:**
  - your breathing problems worsen with ADVAIR HFA
  - you need to use your short-acting beta<sub>2</sub>-agonist medicine more often than usual
  - your short-acting beta<sub>2</sub>-agonist medicine does not work as well for you at relieving symptoms
  - you need to use 4 or more inhalations of your short-acting beta<sub>2</sub>-agonist medicine for 2 or more days in a row
  - you use 1 whole canister of your short-acting beta<sub>2</sub>-agonist medicine in 8 weeks' time
  - your peak flow meter results decrease. Your healthcare provider will tell you the numbers that are right for you.
  - you have asthma and your symptoms do not improve after using ADVAIR HFA regularly for 1 week

#### **What are the possible side effects with ADVAIR HFA?**

**ADVAIR HFA contains salmeterol (the same medicine found in SEREVENT). In patients with asthma, LABA medicines, such as salmeterol, may increase the chance of death from asthma problems.** See “What is the most important information I should know about ADVAIR HFA?”

#### **Other possible side effects with ADVAIR HFA include:**

- **serious allergic reactions including rash; hives; swelling of the face, mouth, and tongue; and breathing problems.** Call your healthcare provider or get emergency medical care if you get any symptoms of a serious allergic reaction.
- **increased blood pressure**
- **a fast and irregular heartbeat**
- **chest pain**
- **headache**
- **tremor**
- **nervousness**
- **immune system effects and a higher chance for infections**
- **lower bone mineral density.** This may be a problem for people who already have a higher chance for low bone density (osteoporosis).
- **eye problems including glaucoma and cataracts.** You should have regular eye exams while using ADVAIR HFA.
- **slowed growth in children.** A child's growth should be checked often.

- **throat irritation**
- **pneumonia.** ADVAIR HFA contains the same medicine found in ADVAIR DISKUS. ADVAIR DISKUS is used to treat people with asthma and people with chronic obstructive pulmonary disease (COPD). People with COPD have a higher chance of getting pneumonia. ADVAIR DISKUS may increase the chance of getting pneumonia. ADVAIR HFA has not been studied in people with COPD.

Common side effects of ADVAIR HFA include upper respiratory tract infection and headache.

Tell your healthcare provider about any side effect that bothers you or that does not go away.

These are not all the side effects with ADVAIR HFA. Ask your healthcare provider or pharmacist for more information.

Call your doctor for medical advice about side effects. You may report side effects to FDA at 1-800-FDA-1088.

### **How should I store ADVAIR HFA?**

Store at room temperature with the mouthpiece down.

**Contents Under Pressure:** Do not puncture. Do not use or store near heat or open flame. Exposure to temperatures above 120°F may cause bursting.

Do not throw into fire or an incinerator.

**Keep ADVAIR HFA and all medicines out of the reach of children.**

### **General information about ADVAIR HFA**

Medicines are sometimes prescribed for purposes other than those listed in a Medication Guide. Do not use ADVAIR HFA for a condition for which it was not prescribed. Do not give your ADVAIR HFA to other people, even if they have the same condition that you have. It may harm them.

This Medication Guide summarizes the most important information about ADVAIR HFA. If you would like more information, talk with your healthcare provider or pharmacist. You can ask your healthcare provider or pharmacist for information about ADVAIR HFA that was written for healthcare professionals. You can also contact the company that makes ADVAIR HFA (toll free) at 1-888-825-5249 or at [www.advair.com](http://www.advair.com).

### **What are the ingredients in ADVAIR HFA?**

Active ingredients: fluticasone propionate, salmeterol xinafoate

Inactive ingredient: propellant HFA-134a

### **How to use your ADVAIR HFA**

#### **The parts of your ADVAIR HFA:**

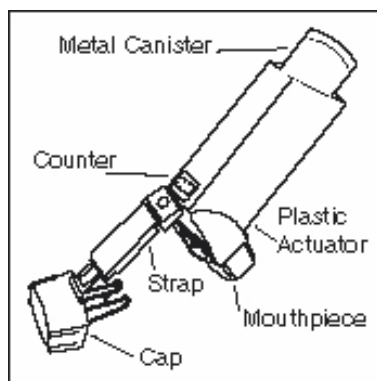

**Figure 1**

There are 2 main parts to your ADVAIR HFA inhaler—the metal canister that holds the medicine and the purple plastic actuator that sprays the medicine from the canister (see Figure 1).

The inhaler also has a cap that covers the mouthpiece of the actuator. The strap on the cap will stay attached to the actuator.

**Do not use the actuator with a canister of medicine from any other inhaler. Do not use an ADVAIR HFA canister with an actuator from any other inhaler.**

The canister has a counter to show how many sprays of medicine you have left. The number shows through a window in the back of the actuator.

The counter starts at 124. The number will count down by 1 each time you spray the inhaler. The counter will stop counting at 000.

**Never try to change the numbers or take the counter off the metal canister.** The counter cannot be reset, and it is permanently attached to the canister.

#### **Before using your ADVAIR HFA:**

Take the inhaler out of the foil pouch. Safely throw away the foil pouch and the drying packet that comes inside the pouch. The counter should read 124.

The inhaler should be at room temperature before you use it.

Check each time to make sure the canister fits firmly in the plastic actuator. Also look into the mouthpiece to make sure there are no foreign objects there, especially if the strap is no longer attached to the actuator or if the cap is not being used to cover the mouthpiece.

#### **Priming your ADVAIR HFA:**

Before you use ADVAIR HFA for the first time, you must prime the inhaler so that you will get the right amount of medicine when you use it. To prime the inhaler, take the cap off the mouthpiece and shake the inhaler well for 5 seconds. Then spray it 1 time into the air away from your face. Shake and spray the inhaler like this 3 more times to finish priming it. **Avoid spraying in eyes.** The counter should now read 120.

You must prime your inhaler again if you have not used it in more than 4 weeks or if you have dropped it. Take the cap off the mouthpiece, shake the inhaler well for 5 seconds, and spray it into the air away from your face. Shake and spray the inhaler like this 1 more time to finish priming it.

#### **Instructions for taking a dose from your ADVAIR HFA:**

Read through the 7 steps below before using ADVAIR HFA. If you have any questions, ask your doctor or pharmacist.

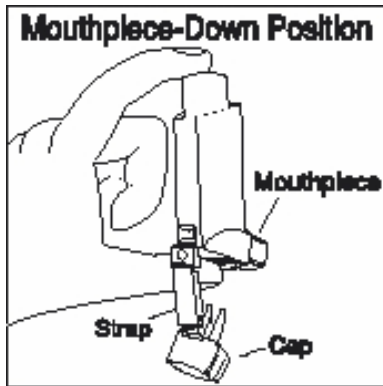

Figure 2

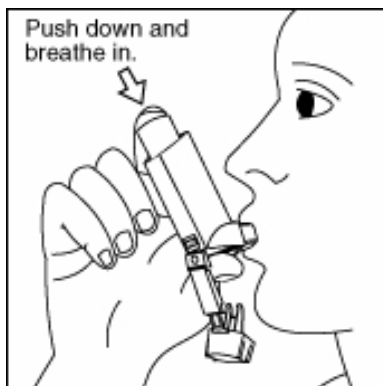

Figure 3

1. Take the cap off the mouthpiece of the actuator. **Shake the inhaler well** for 5 seconds before each spray.
2. Hold the inhaler with the mouthpiece down (see Figure 2). **Breathe out through your mouth** and push as much air from your lungs as you can. Put the mouthpiece in your mouth and close your lips around it.
3. **Push the top of the canister all the way down while you breathe in deeply and slowly through your mouth** (see Figure 3). Right after the spray comes out, take your finger off the canister. After you have breathed in all the way, take the inhaler out of your mouth and close your mouth.
4. **Hold your breath as long as you can**, up to 10 seconds, then breathe normally.
5. Wait about 30 seconds and **shake** the inhaler again for 5 seconds. Repeat steps 2 through 4.
6. After you finish taking this medicine, rinse your mouth with water. Spit out the water. Do not swallow it.
7. Put the cap back on the mouthpiece after every time you use the inhaler, and make sure it snaps firmly into place.

**When to replace your ADVAIR HFA:**

- **When the counter reads 020**, you should refill your prescription or ask your doctor if you need another prescription for ADVAIR HFA.
- **Throw the inhaler away** when the counter reads **000**. You should not keep using the inhaler when the counter reads 000 because you will not receive the right amount of medicine.
- **Do not use the inhaler** after the expiration date, which is on the packaging it comes in.

**How to clean your ADVAIR HFA:**

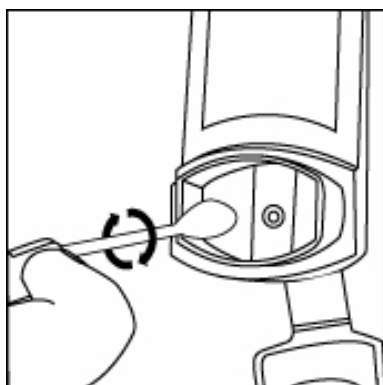

Figure 4

Clean the inhaler at least once a week after your evening dose. It is important to keep the canister and plastic actuator clean so the medicine will not build-up and block the spray.

1. Take the cap off the mouthpiece. The strap on the cap will stay attached to the actuator. Do not take the canister out of the plastic actuator.
2. Use a dry cotton swab to clean the small circular opening where the medicine sprays out of the canister. Carefully twist the swab in a circular motion to take off any medicine (see Figure 4).

3. Wipe the inside of the mouthpiece with a clean tissue dampened with water. Let the actuator air-dry overnight.
4. Put the cap back on the mouthpiece after the actuator has dried.

**This Medication Guide has been approved by the U.S. Food and Drug Administration.**

ADVAIR, ADVAIR DISKUS, DISKUS, FLOVENT, and SEREVENT are registered trademarks of GlaxoSmithKline.

The other brands listed are trademarks of their respective owners and are not trademarks of GlaxoSmithKline. The makers of these brands are not affiliated with and do not endorse GlaxoSmithKline or its products.



GlaxoSmithKline  
Research Triangle Park, NC 27709

©2008, GlaxoSmithKline. All rights reserved.

November 2008

ADH:3MG